

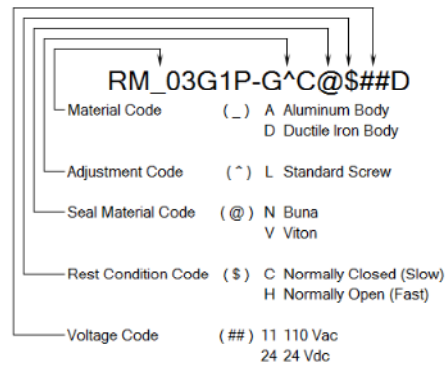

DWG NO	RM_03G1P-G^C@\$\$#D	REV	-
MODEL CODE	RM_03G1P-G^C@\$\$#D		
PROPRIETARY NOTICE	THIS DRAWING DESCRIBES A PROPRIETARY PRODUCT OF LYNCH FLUID CONTROLS INC. WHICH MAY NOT BE REPRODUCED IN WHOLE OR IN PART NOR GIVEN TO A THIRD PARTY WITHOUT WRITTEN PERMISSION FROM LYNCH FLUID CONTROLS INC.		
TITLE	2 Speed D03 Sandwich Module M/I P Pilot Operated Poppet Needle		
DATA UNIT: INCH	3RD ANGLE PROJECTION		

MODEL CODE BREAKDOWN



Bill of Material		
ITEM	QTY	DESCRIPTION
1	1	Manifold Body
2	1	Seal Plate
3	1	[Flow Control] Fully adjustable needle valve
4	1	[Main Stage] 2-way, poppet directional valve with integral T-8A control cavity - control 1-2
5	1	[Solenoid] 2-way, solenoid-operated directional spool valve - pilot capacity
6	1	Coil
7	1	Connector
8	1	Nameplate
9	4	Screws

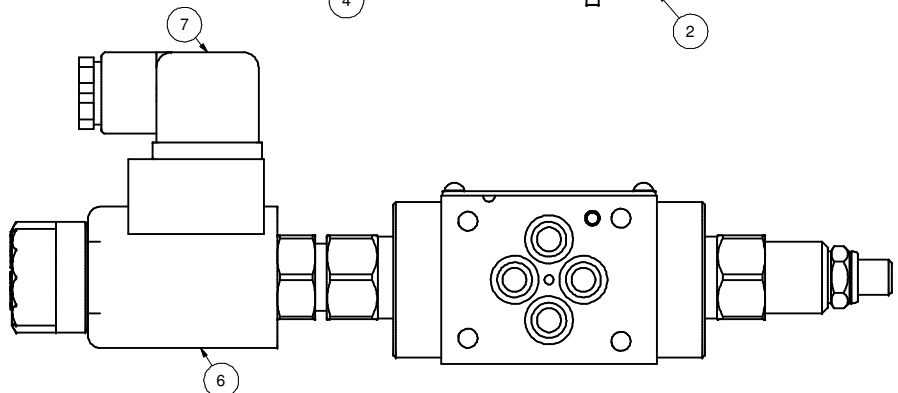
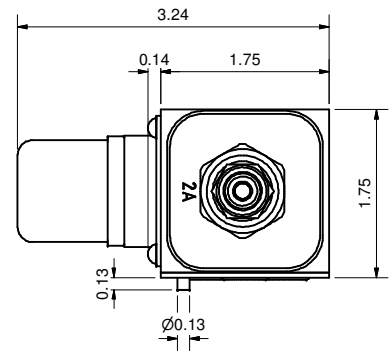
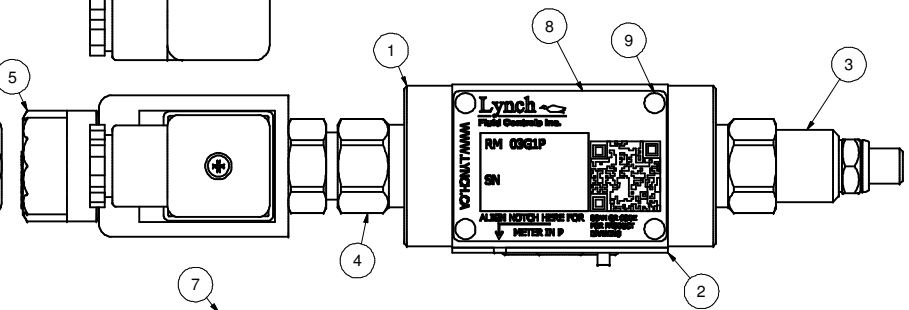
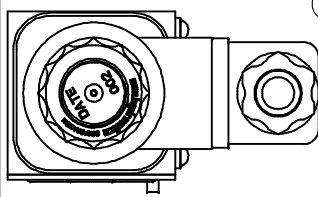
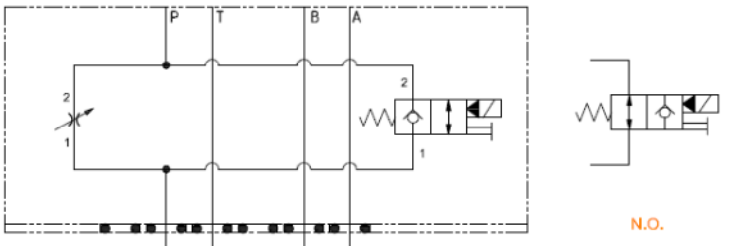
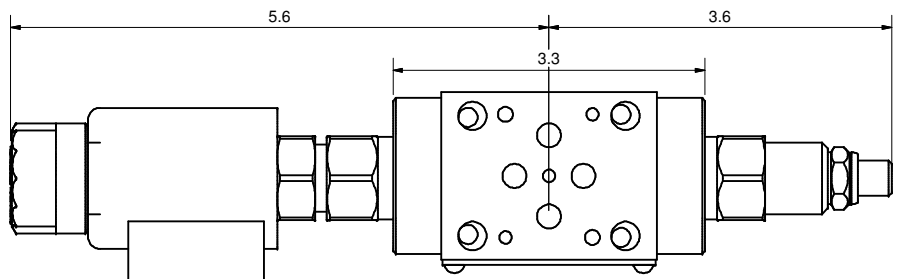
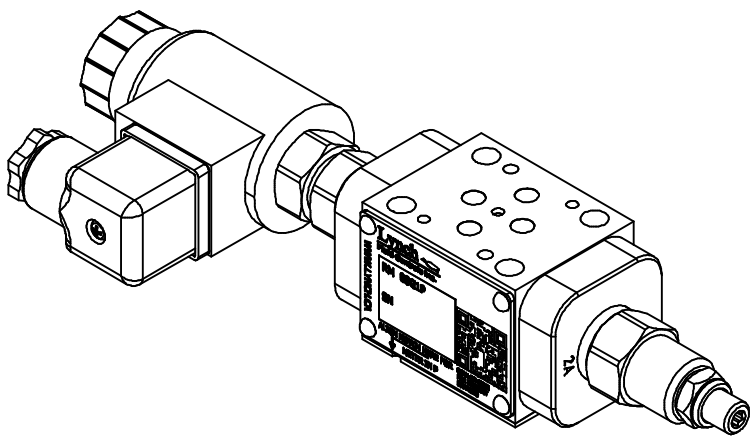



DWG NO	RM_03G1P-G^C@\$\$#D	REV	-
MODEL CODE	RM_03G1P-G^C@\$\$#D		
PROPRIETARY NOTICE THIS DRAWING DESCRIBES A PROPRIETARY PRODUCT OF LYNCH FLUID CONTROLS INC. WHICH MAY NOT BE REPRODUCED IN WHOLE OR IN PART NOR GIVEN TO A THIRD PARTY WITHOUT WRITTEN PERMISSION FROM LYNCH FLUID CONTROLS INC.		TITLE 2 Speed D03 Sandwich Module M/O T Pilot Operated Poppet Needle	
DATA UNIT: INCH	3RD ANGLE PROJECTION		

MODEL CODE BREAKDOWN

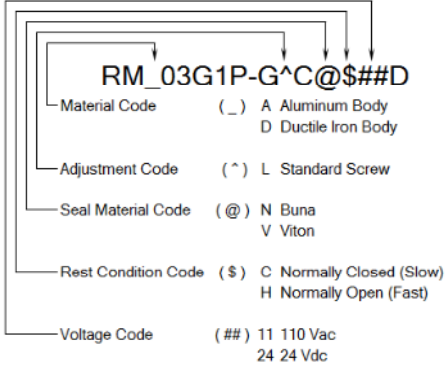

Bill of Material		
ITEM	QTY	DESCRIPTION
1	1	Manifold Body
2	1	Seal Plate
3	1	[Flow Control] Fully adjustable needle valve
4	1	[Main Stage] 2-way, poppet directional valve with integral T-8A control cavity - control 1-2
5	1	[Solenoid] 2-way, solenoid-operated directional spool valve - pilot capacity
6	1	Coil
7	1	Connector
8	1	Nameplate
9	4	Screws

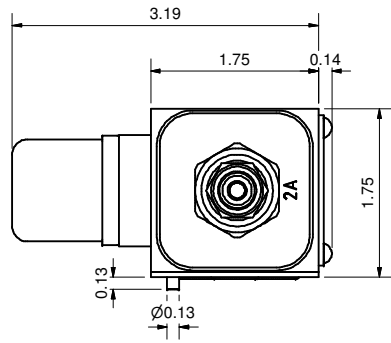
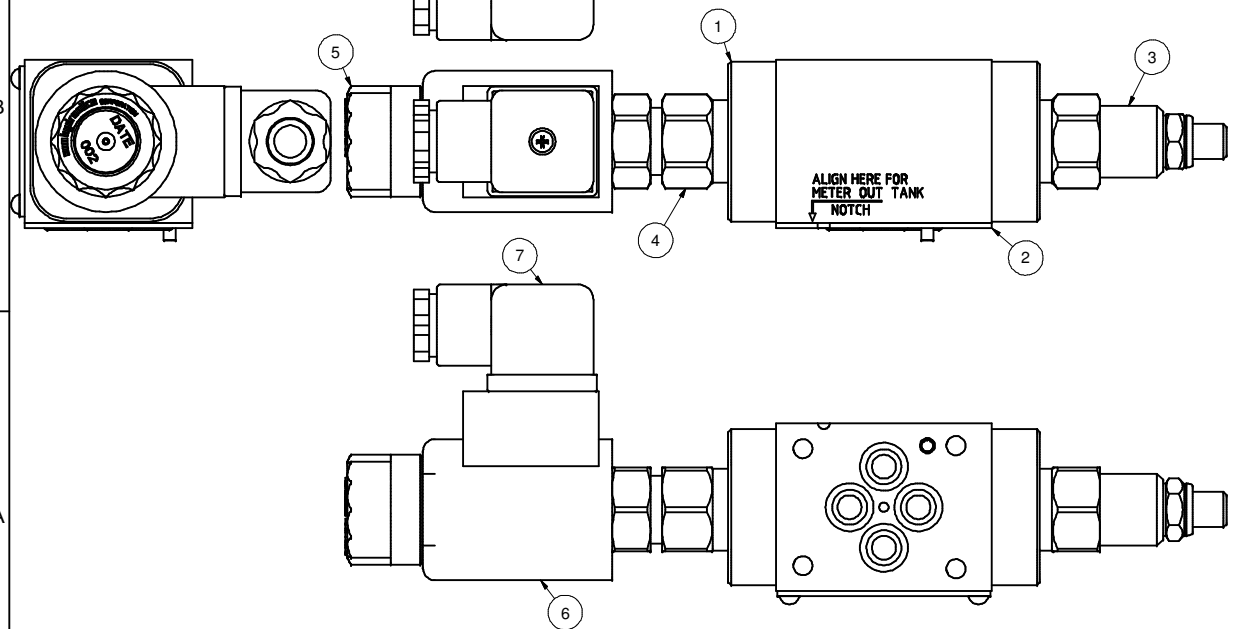
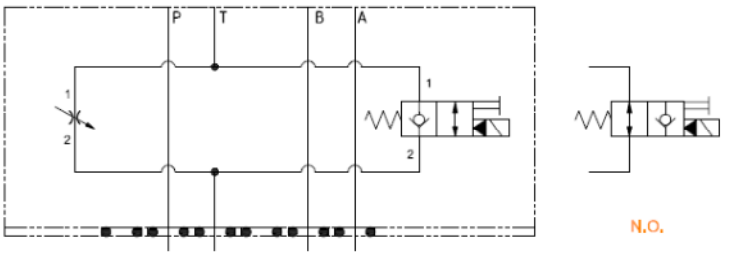
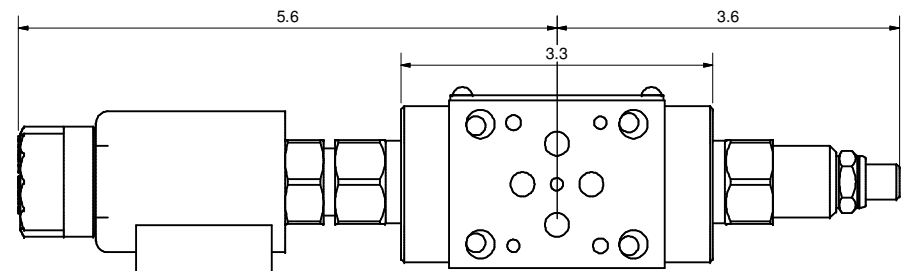
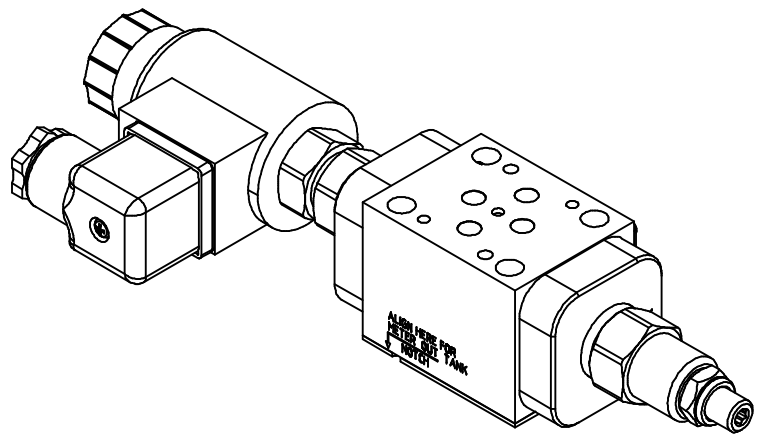

L - Standard Screw

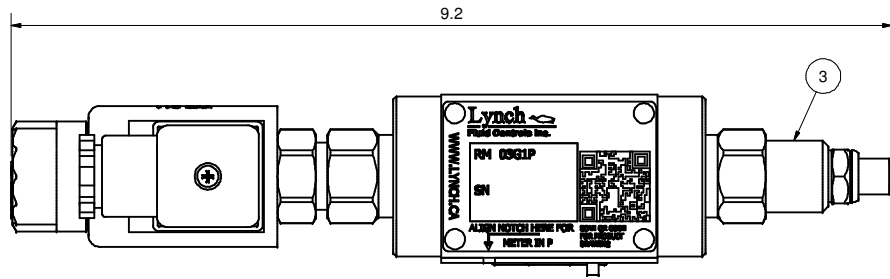

K - Hand-Knob

Non-Standard Option: Order Standard L control w/ 991 211 Kit

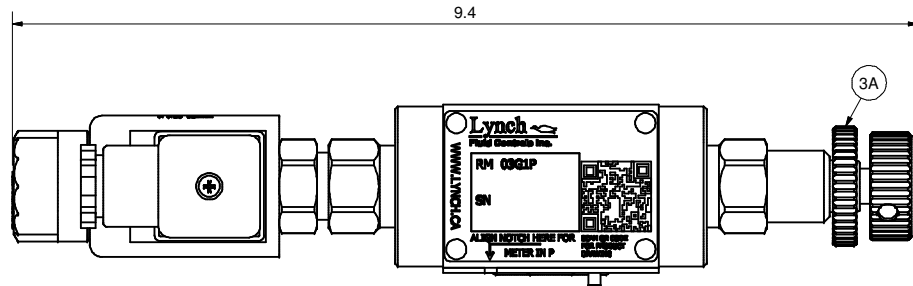

H - Calibrated Hand-Knob

Non-Standard Option

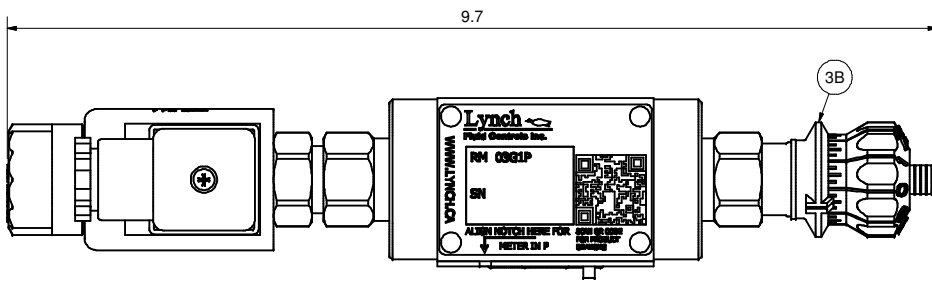

DWG NO RM_03G1P-G^C@\$\$#D REV -

MODEL CODE RM_03G1P-G^C@\$\$#D

PROPRIETARY NOTICE
THIS DRAWING DESCRIBES A PROPRIETARY PRODUCT OF LYNCH FLUID CONTROLS INC. WHICH MAY NOT BE REPRODUCED IN WHOLE OR IN PART NOR GIVEN TO A THIRD PARTY WITHOUT WRITTEN PERMISSION FROM LYNCH FLUID CONTROLS INC.

TITLE
Technical Data & Non-Standard Options

DATA UNIT: INCH 3RD ANGLE PROJECTION

ITEM QTY		DESCRIPTION
3	1	[Flow Control] Fully adjustable needle valve
3A	1	[Flow Control] Fully adjustable needle valve [Hand-Knob]
3B	1	[Flow Control] Fully adjustable needle valve [Calibrated Hand-Knob]

Flow Control

Adjustment Sensitivity at 100 psi Differential

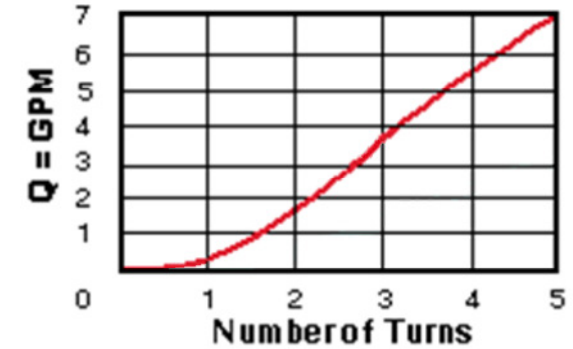

Main Stage

PSI Pressure Differential vs Flow

