

DWG NO RM_03G1A-P^A@\$##D

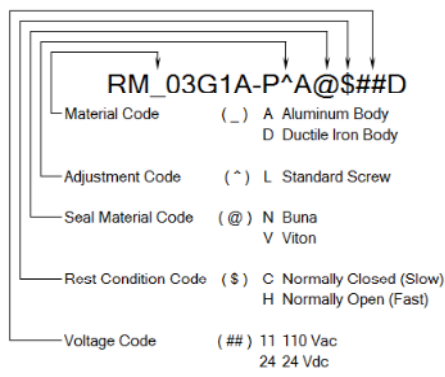

DWG NO	RM_03G1A-P^A@\$##D	REV	-
MODEL CODE	RM_03G1A-P^A@\$##D		
PROPRIETARY NOTICE	<small>THIS DRAWING DESCRIBES A PROPRIETARY PRODUCT OF LYNCH FLUID CONTROLS INC. WHICH MAY NOT BE REPRODUCED IN WHOLE OR IN PART NOR GIVEN TO A THIRD PARTY WITHOUT WRITTEN PERMISSION FROM LYNCH FLUID CONTROLS INC.</small>		
TITLE	2 Speed D03 Sandwich Module M/O A Pilot Operated Poppet PC Flow Control		
DATA UNIT: INCH	3RD ANGLE PROJECTION		

MODEL CODE BREAKDOWN



ITEM QTY		DESCRIPTION
1	1	Manifold Body
2	1	Seal Plate
3	1	[Flow Control] Fully adjustable pressure compensated flow control valve with reverse flow check
4	1	[Main Stage] 2-way, poppet directional valve with integral T-8A control cavity - control 1-2
5	1	[Solenoid] 2-way, solenoid-operated directional spool valve - pilot capacity
6	1	Coil
7	1	Connector
8	1	Nameplate
9	4	Screws

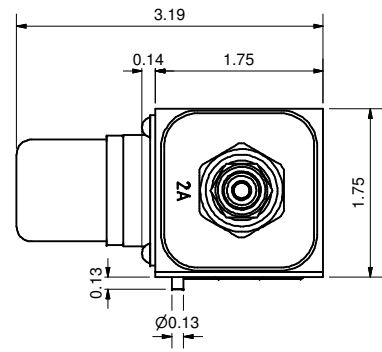
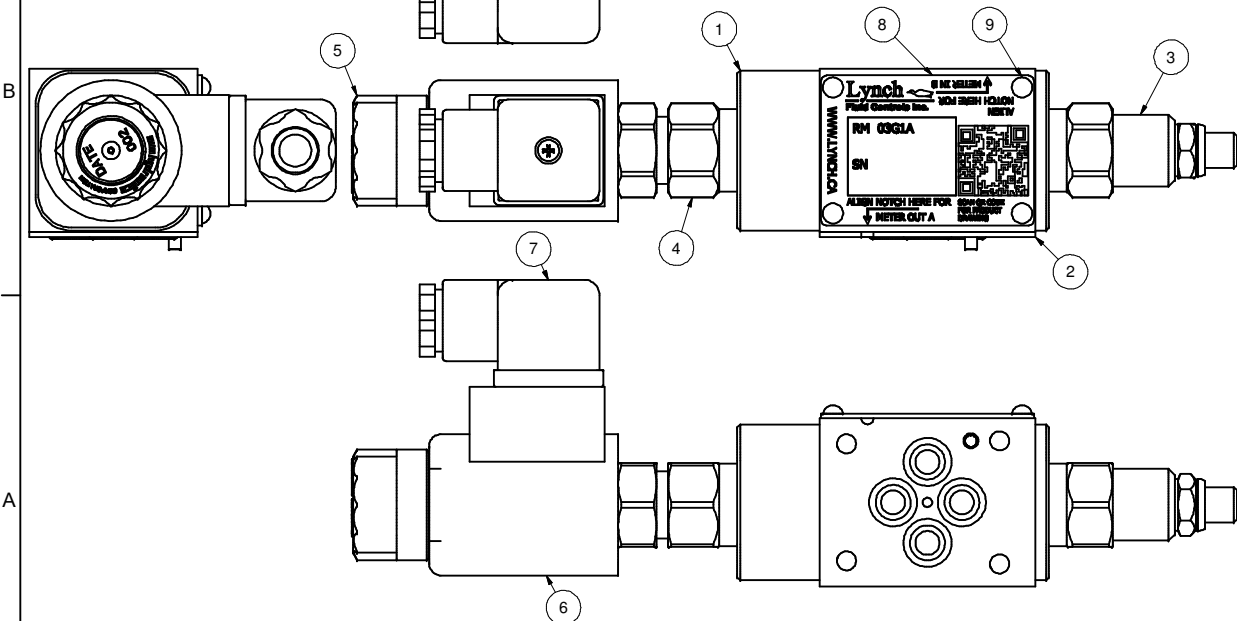
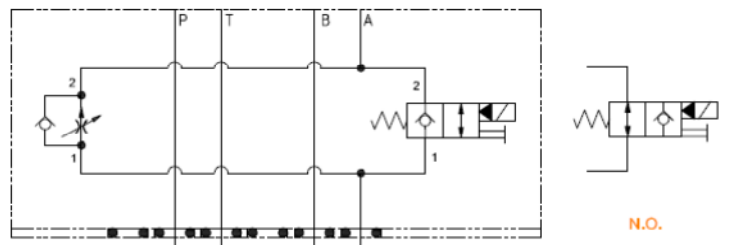
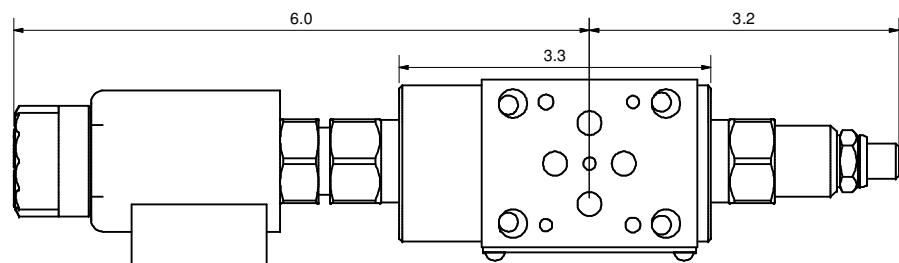
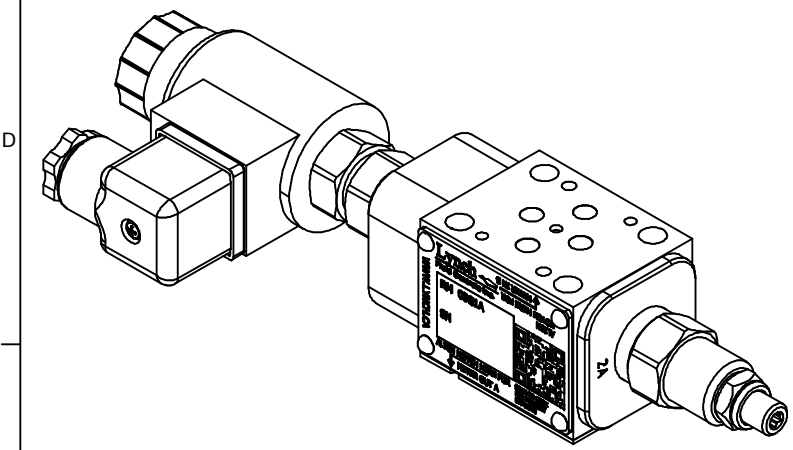



DWG NO	RM_03G1A-P^A@\$\$#D	REV	-
MODEL CODE	RM_03G1A-P^A@\$\$#D		
PROPRIETARY NOTICE	THIS DRAWING DESCRIBES A PROPRIETARY PRODUCT OF LYNCH FLUID CONTROLS INC. WHICH MAY NOT BE REPRODUCED IN WHOLE OR IN PART NOR GIVEN TO A THIRD PARTY WITHOUT WRITTEN PERMISSION FROM LYNCH FLUID CONTROLS INC.		
TITLE	2 Speed D03 Sandwich Module M/I A Pilot Operated Poppet PC Flow Control		
DATA UNIT: INCH	3RD ANGLE PROJECTION		

MODEL CODE BREAKDOWN

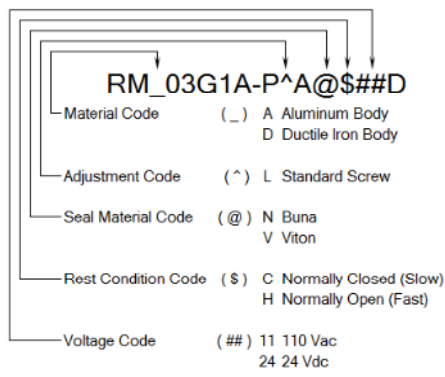

ITEM QTY		DESCRIPTION
1	1	Manifold Body
2	1	Seal Plate
3	1	[Flow Control] Fully adjustable pressure compensated flow control valve with reverse flow check
4	1	[Main Stage] 2-way, poppet directional valve with integral T-8A control cavity - control 1-2
5	1	[Solenoid] 2-way, solenoid-operated directional spool valve - pilot capacity
6	1	Coil
7	1	Connector
8	1	Nameplate
9	4	Screws

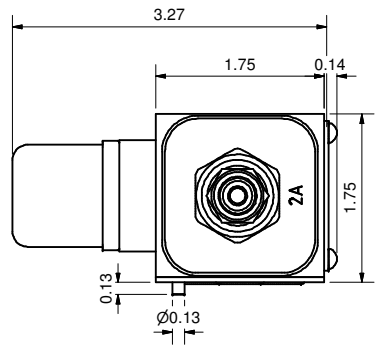
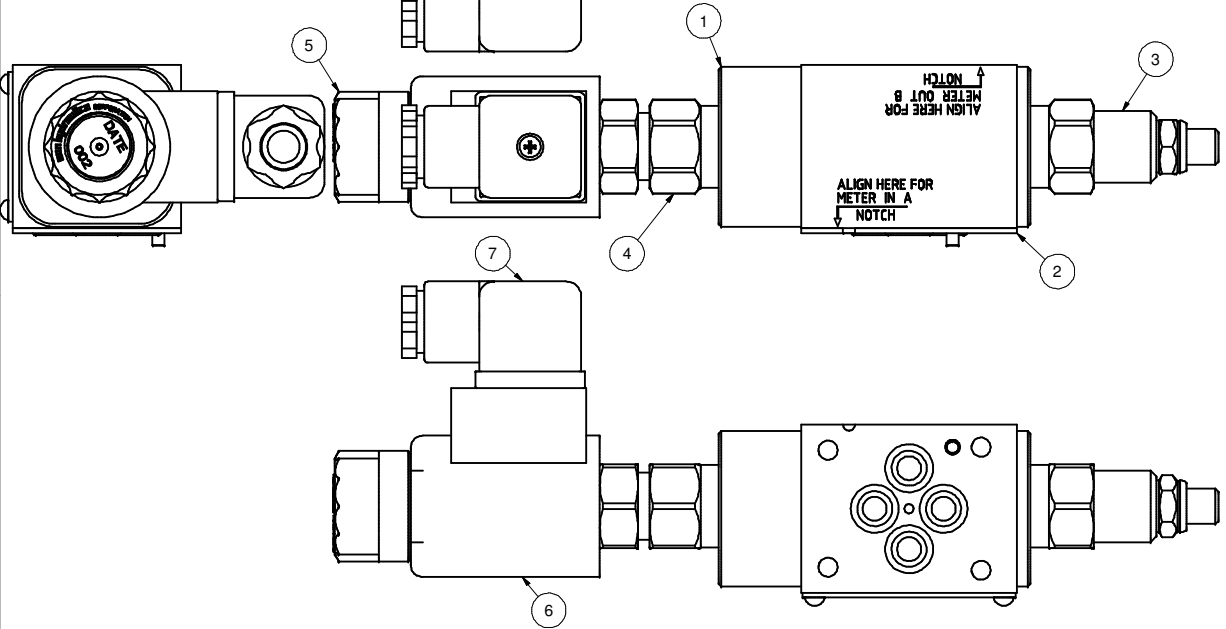
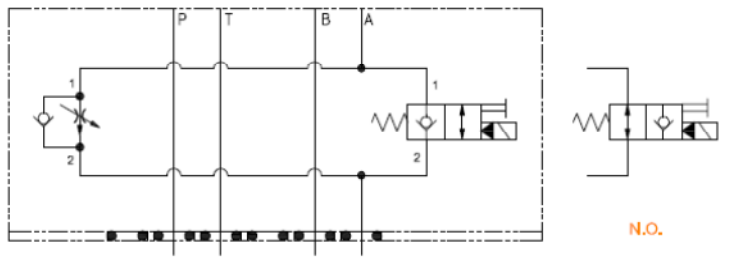
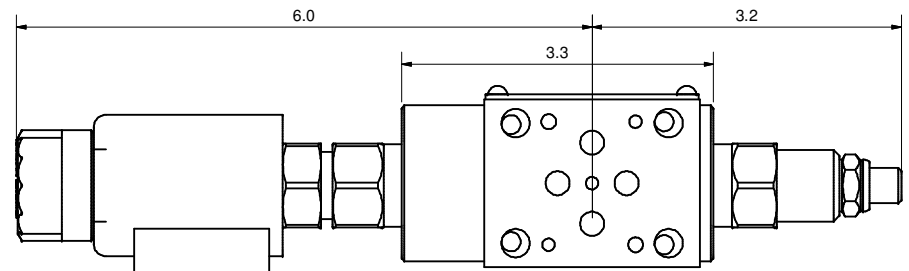
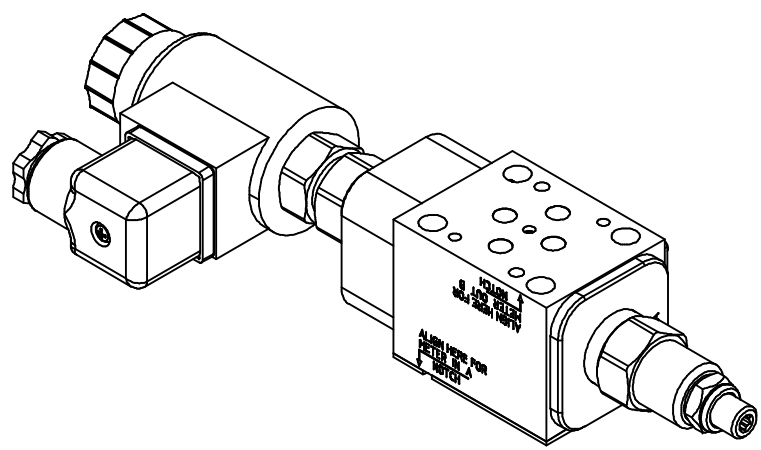

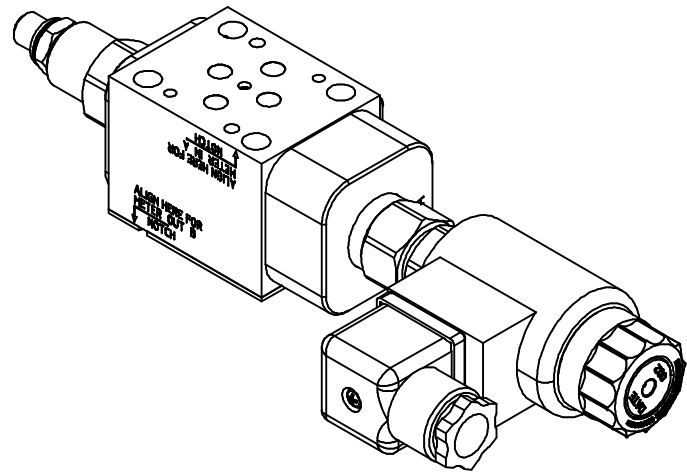

MODEL CODE BREAKDOWN

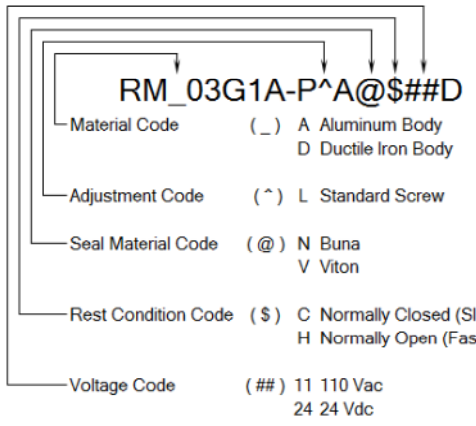

DWG NO	RM_03G1A-P^A@\$\$#D	REV	-
MODEL CODE	RM_03G1A-P^A@\$\$#D		
TITLE	2 Speed D03 Sandwich Module M/O B Pilot Operated Poppet PC Flow Control		

PROPRIETARY NOTICE
THIS DRAWING DESCRIBES A PROPRIETARY PRODUCT OF LYNCH FLUID CONTROLS INC. WHICH MAY NOT BE REPRODUCED IN WHOLE OR IN PART NOR GIVEN TO A THIRD PARTY WITHOUT WRITTEN PERMISSION FROM LYNCH FLUID CONTROLS INC.

DATA UNIT:	INCH	3RD ANGLE PROJECTION	
------------	------	----------------------	--

ITEM QTY		DESCRIPTION
1	1	Manifold Body
2	1	Seal Plate
3	1	[Flow Control] Fully adjustable pressure compensated flow control valve with reverse flow check
4	1	[Main Stage] 2-way, poppet directional valve with integral T-8A control cavity - control 1-2
5	1	[Solenoid] 2-way, solenoid-operated directional spool valve - pilot capacity
6	1	Coil
7	1	Connector
8	1	Nameplate
9	4	Screws

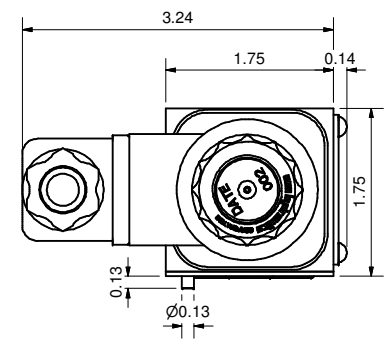
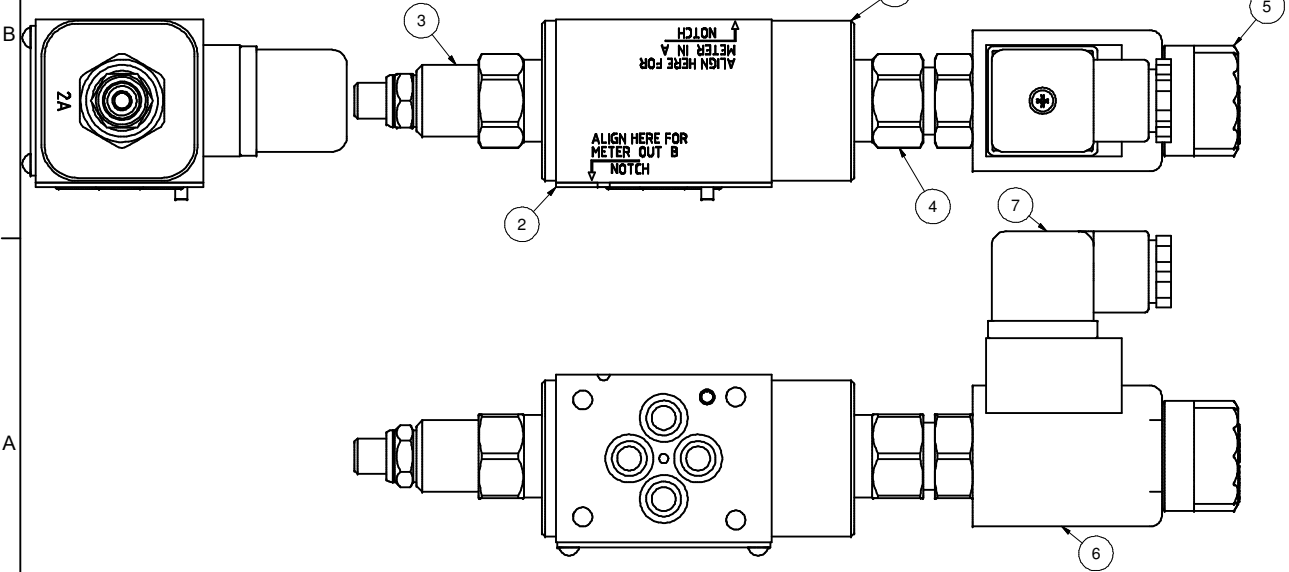
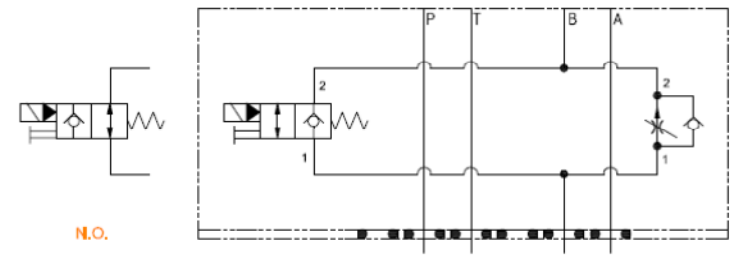
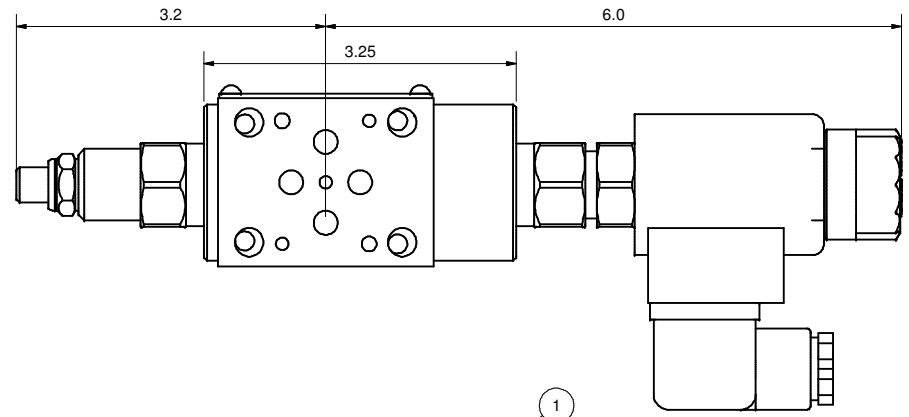

DWG NO RM_03G1A-P^A@\$\$#D



DWG NO	RM_03G1A-P^A@\$\$#D	REV	-
MODEL CODE	RM_03G1A-P^A@\$\$#D		
TITLE	2 Speed D03 Sandwich Module M/I B Pilot Operated Poppet PC Flow Control		

PROPRIETARY NOTICE
THIS DRAWING DESCRIBES A PROPRIETARY PRODUCT OF LYNCH FLUID CONTROLS INC. WHICH MAY NOT BE REPRODUCED IN WHOLE OR IN PART NOR GIVEN TO A THIRD PARTY WITHOUT WRITTEN PERMISSION FROM LYNCH FLUID CONTROLS INC.

DATA UNIT:	INCH	3RD ANGLE PROJECTION
------------	------	----------------------

ITEM QTY		DESCRIPTION
1	1	Manifold Body
2	1	Seal Plate
3	1	[Flow Control] Fully adjustable pressure compensated flow control valve with reverse flow check
4	1	[Main Stage] 2-way, poppet directional valve with integral T-8A control cavity - control 1-2
5	1	[Solenoid] 2-way, solenoid-operated directional spool valve - pilot capacity
6	1	Coil
7	1	Connector
8	1	Nameplate
9	4	Screws

MODEL CODE BREAKDOWN

RM_03G1A-P^A@\$\$#D

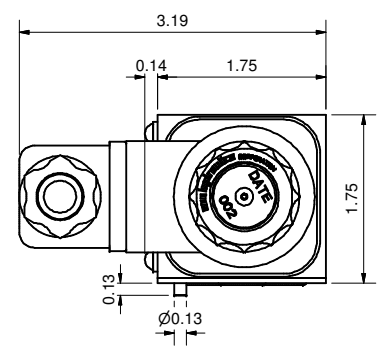
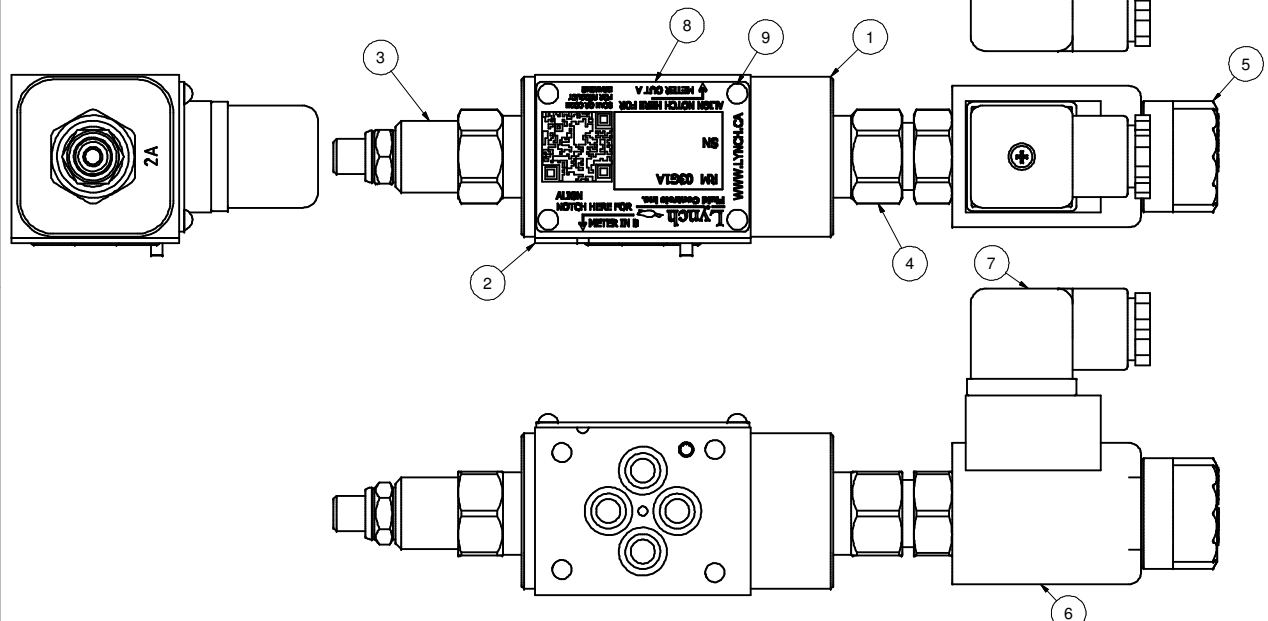
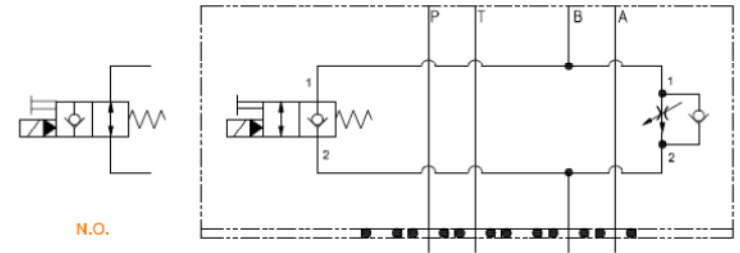
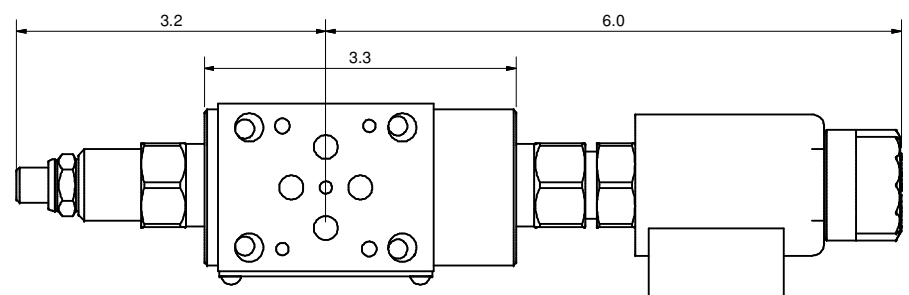
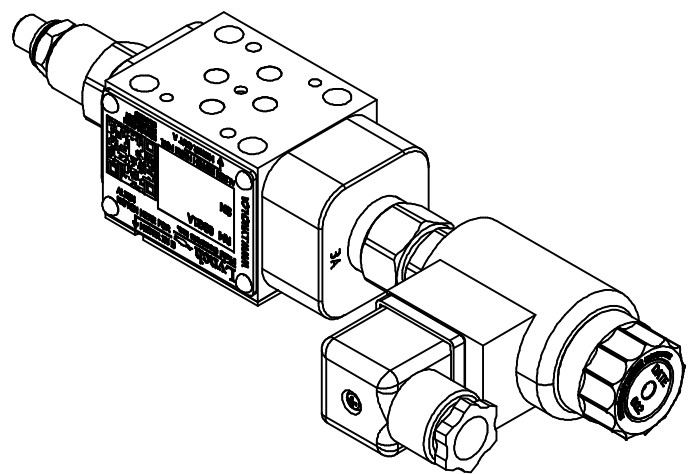
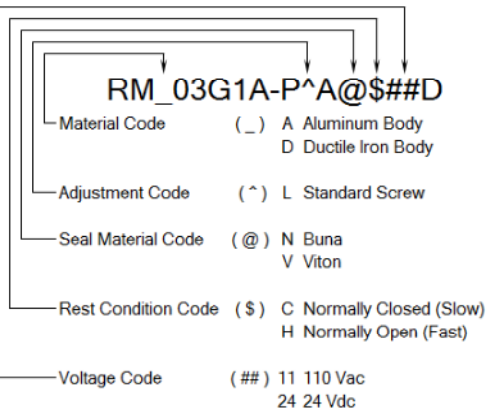

L - Standard Screw

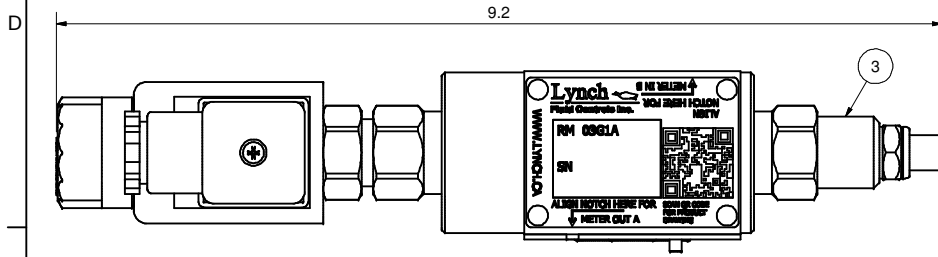

K - Hand-Knob

Non-Standard Option: Order Standard L control w/ 991 211 Kit

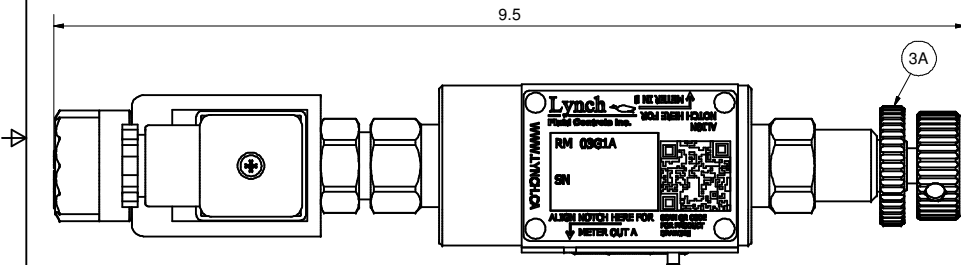

H - Calibrated Hand-Knob

Non-Standard Option

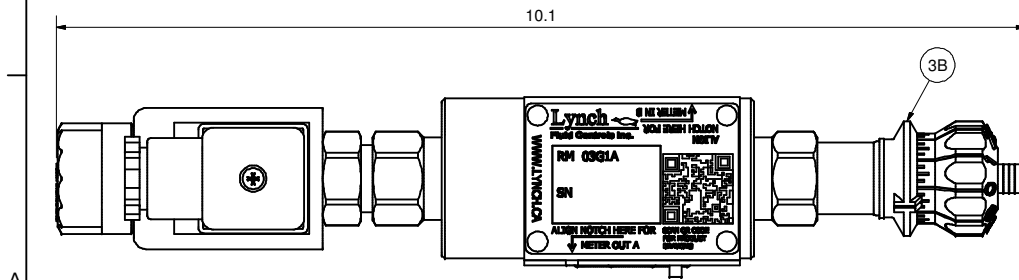

DWG NO	RM_03G1A-P^A@\$##D	REV	-
MODEL CODE	RM_03G1A-P^A@\$##D		
PROPRIETARY NOTICE THIS DRAWING DESCRIBES A PROPRIETARY PRODUCT OF LYNCH FLUID CONTROLS INC. WHICH MAY NOT BE REPRODUCED IN WHOLE OR IN PART NOR GIVEN TO A THIRD PARTY WITHOUT WRITTEN PERMISSION FROM LYNCH FLUID CONTROLS INC.		TITLE Technical Data & Non-Standard Options	
DATA UNIT: INCH	3RD ANGLE PROJECTION		

ITEM QTY		DESCRIPTION
3	1	[Flow Control] Fully adjustable pressure compensated flow control valve with reverse flow check
3A	1	[Flow Control] Fully adjustable pressure compensated flow control valve with reverse flow check [Hand-Knob]
3B	1	[Flow Control] Fully adjustable pressure compensated flow control valve with reverse flow check [Calibrated Hand-Knob]

Flow Control

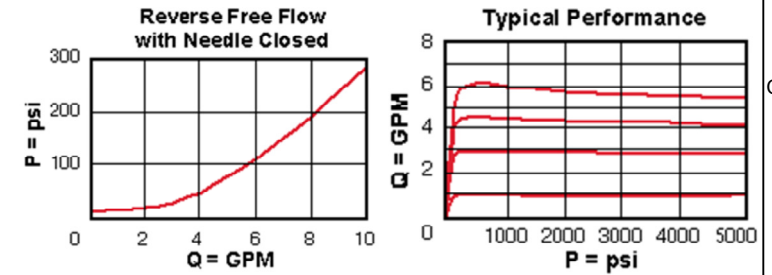

Main Stage

