

MODEL CODE BREAKDOWN

RM_03G1P-E^C@\$\$#D

- Material Code (_) A Aluminum Body
D Ductile Iron Body
- Adjustment Code (^) L Standard Screw
- Seal Material Code (@) N Buna
V Viton
- Rest Condition Code (\$) C Normally Closed (Slow)
H Normally Open (Fast)
- Voltage Code (##) 11 110 Vac
24 24 Vdc



DWG NO	RM_03G1P-E^C@\$\$#D	REV	-
MODEL CODE	RM_03G1P-E^C@\$\$#D		
PROPRIETARY NOTICE	THIS DRAWING DESCRIBES A PROPRIETARY PRODUCT OF LYNCH FLUID CONTROLS INC. WHICH MAY NOT BE REPRODUCED IN WHOLE OR IN PART NOR GIVEN TO A THIRD PARTY WITHOUT WRITTEN PERMISSION FROM LYNCH FLUID CONTROLS INC.		
TITLE	2 Speed D03 Sandwich Module M/I P Direct Acting Spool Needle		
DATA UNIT: INCH	3RD ANGLE PROJECTION		

ITEM QTY		DESCRIPTION
1	1	Manifold Body
2	1	Seal Plate
3	1	[Flow Control] Fully adjustable needle valve
4	1	[Solenoid] 2-way, solenoid-operated directional spool valve
5	1	Coil
6	1	Connector
7	1	Nameplate
8	4	Screws

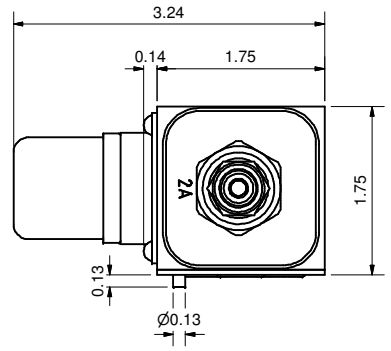
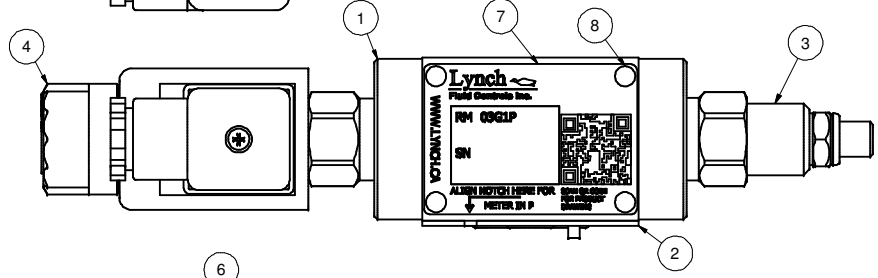
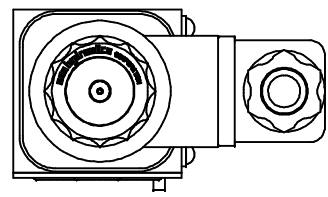
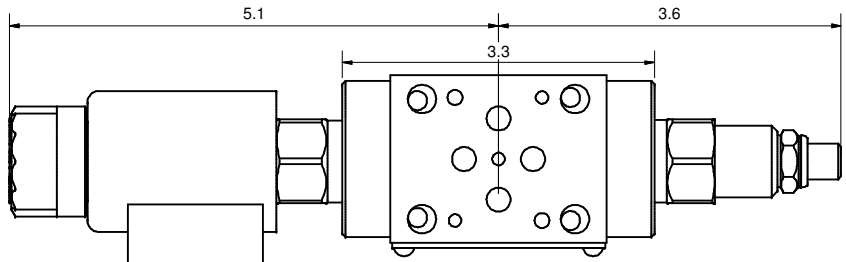
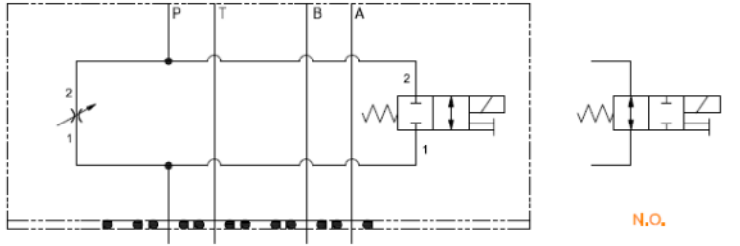

DWG NO. RM_03G1P-E^C@\$\$#D

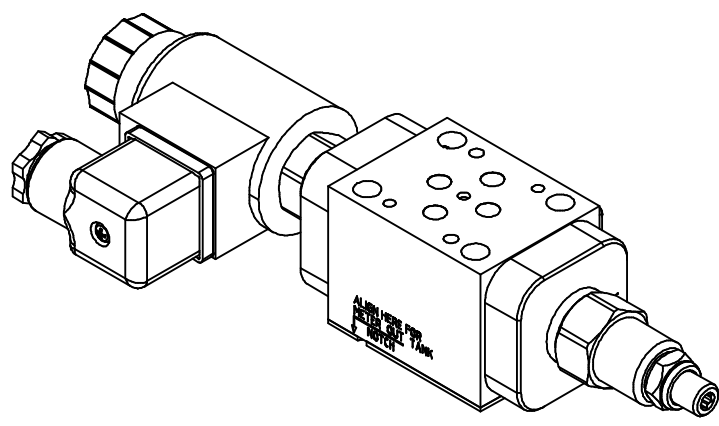

MODEL CODE BREAKDOWN

RM_03G1P-E^C@\$\$#D

- Material Code () A Aluminum Body
D Ductile Iron Body
- Adjustment Code (^) L Standard Screw
- Seal Material Code (@) N Buna
V Viton
- Rest Condition Code (\$) C Normally Closed (Slow)
H Normally Open (Fast)
- Voltage Code (##) 11 110 Vac
24 24 Vdc



DWG NO	RM_03G1P-E^C@\$\$#D	REV	-
MODEL CODE	RM_03G1P-E^C@\$\$#D		
PROPRIETARY NOTICE	THIS DRAWING DESCRIBES A PROPRIETARY PRODUCT OF LYNCH FLUID CONTROLS INC. WHICH MAY NOT BE REPRODUCED IN WHOLE OR IN PART NOR GIVEN TO A THIRD PARTY WITHOUT WRITTEN PERMISSION FROM LYNCH FLUID CONTROLS INC.		
TITLE	2 Speed D03 Sandwich Module M/O T Direct Acting Spool Needle		
DATA UNIT: INCH	3RD ANGLE PROJECTION		

ITEM QTY		DESCRIPTION
1	1	Manifold Body
2	1	Seal Plate
3	1	[Flow Control] Fully adjustable needle valve
4	1	[Solenoid] 2-way, solenoid-operated directional spool valve
5	1	Coil
6	1	Connector
7	1	Nameplate
8	4	Screws

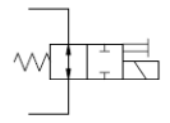
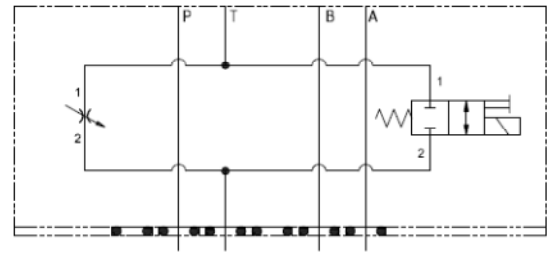
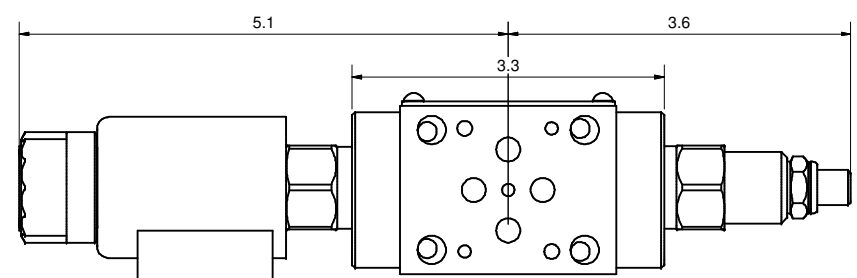

N.O.

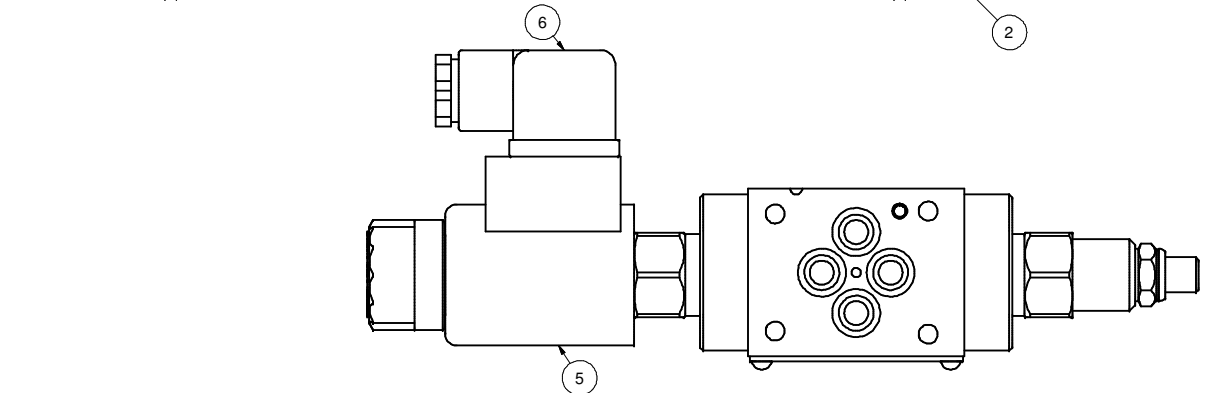
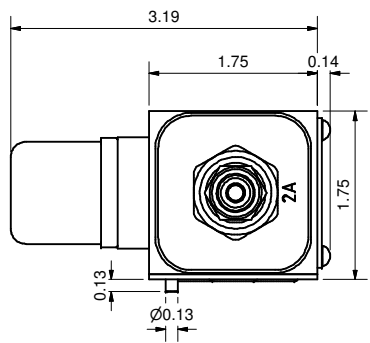
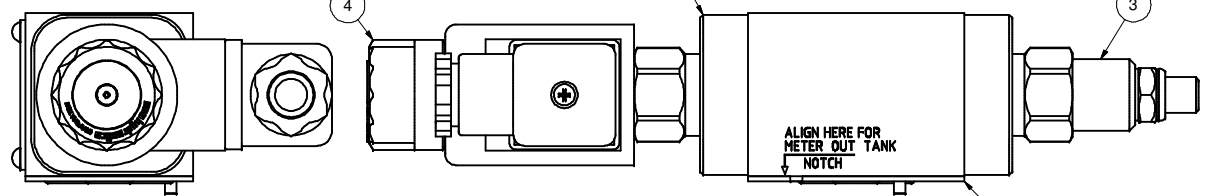

ALIGN HERE FOR METER OUT TANK NOTCH

L - Standard Screw

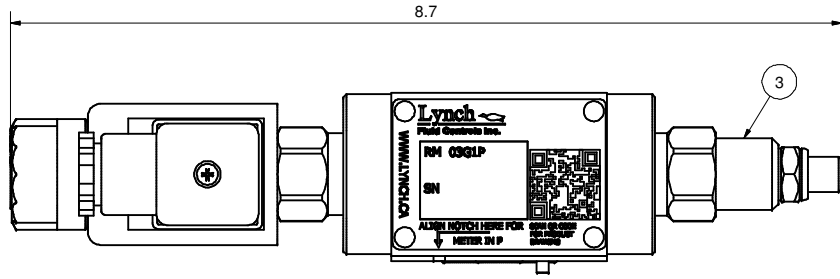

K - Hand-Knob

Non-Standard Option: Order Standard L control w/ 991 211 Kit

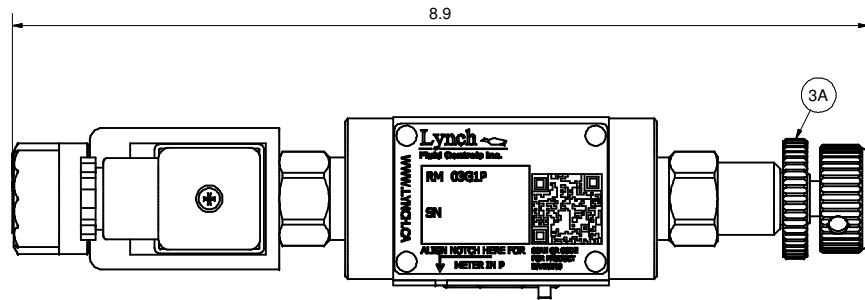

H - Calibrated Hand-Knob

Non-Standard Option

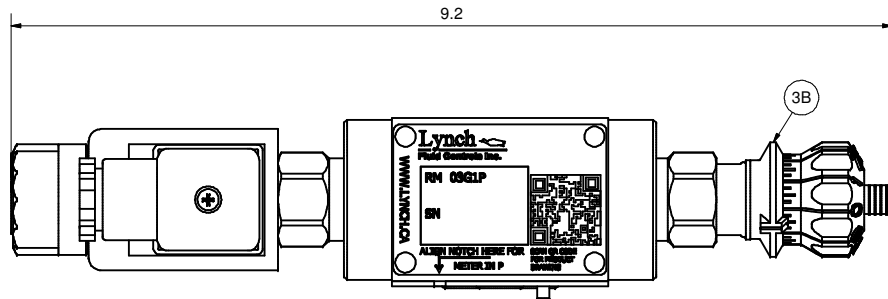

DWG NO	RM_03G1P-E^C@\$\$#D	REV	-
MODEL CODE	RM_03G1P-E^C@\$\$#D		
PROPRIETARY NOTICE THIS DRAWING DESCRIBES A PROPRIETARY PRODUCT OF LYNCH FLUID CONTROLS INC. WHICH MAY NOT BE REPRODUCED IN WHOLE OR IN PART NOR GIVEN TO A THIRD PARTY WITHOUT WRITTEN PERMISSION FROM LYNCH FLUID CONTROLS INC.		TITLE Technical Data & Non-Standard Options	
DATA UNIT:	INCH	3RD ANGLE PROJECTION	

ITEM QTY		DESCRIPTION
3	1	[Flow Control] Fully adjustable needle valve
3A	1	[Flow Control] Fully adjustable needle valve [Hand-Knob]
3B	1	[Flow Control] Fully adjustable needle valve [Calibrated Hand-Knob]

Flow Control

Adjustment Sensitivity at 100 psi Differential

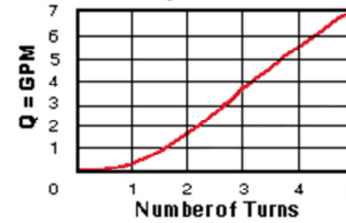

Solenoid

Valve Performance Limits @ 10% Undervoltage & Stabilized Coil Temp.

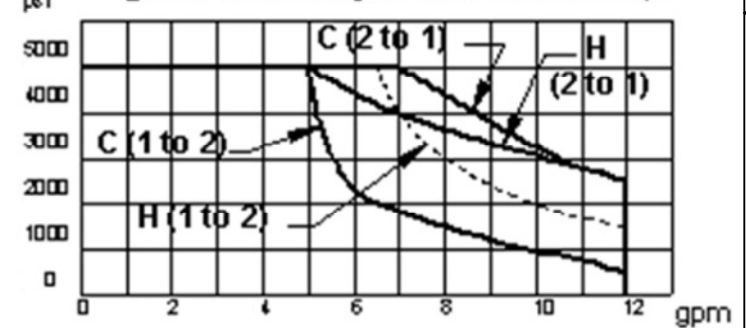

Typical Performance Pressure Differential vs. Flow

