

D07 Standard Flow Parallel Circuit Manifold

(See Page 1.99.01 for Relief Cartridges)

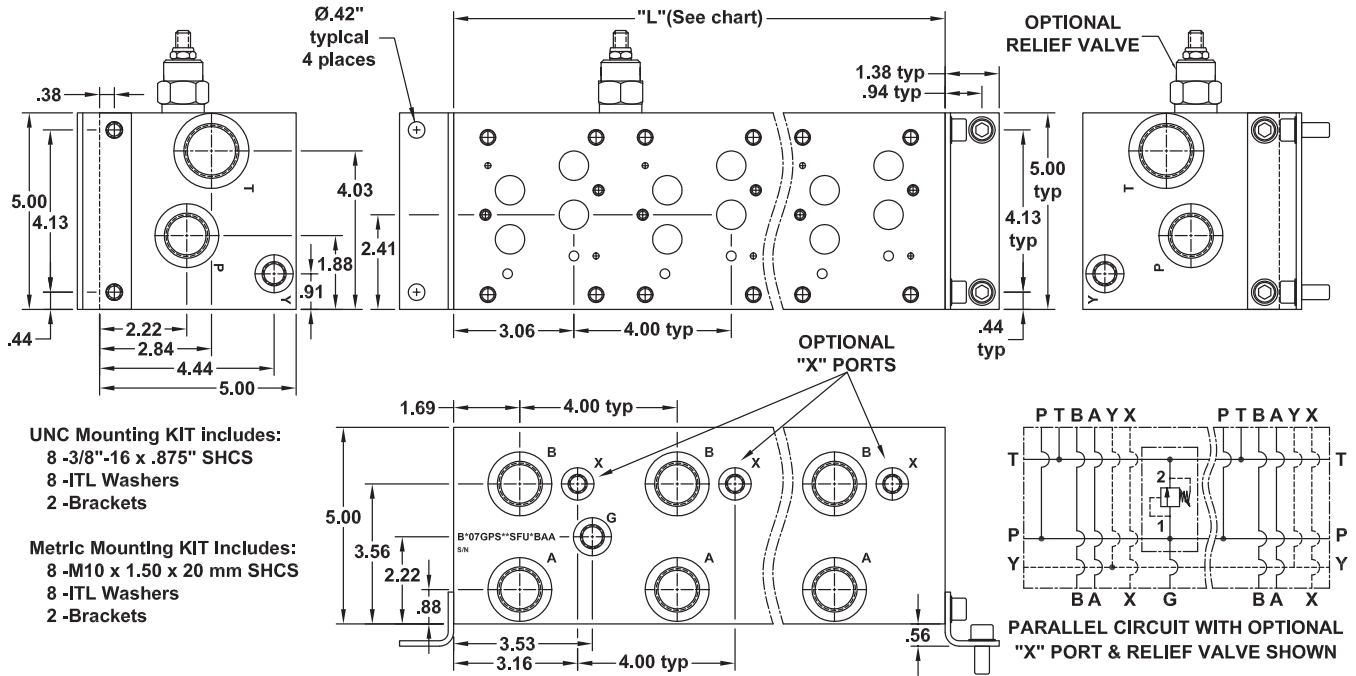

No. of Stations	1	2	3	4	5	6	7	8
Dim. "L", 4.00" spacing	4.50	8.50	12.50	16.50	20.50	24.50	28.50	32.50
est. weight in lb.- alum	9	16	24	31	38	45	52	60
est. weight in lb.- iron	23	42	62	81	101	120	140	159

Notes:

- 1) Isolations on P & T available - See Page 5 for Codes
- 2) Common X port option available - contact factory for P/N
- 3) Larger relief cavities available - contact factory for P/N

PART NUMBER SYSTEM

Aluminum D07 with Common Y and SAE porting example: **BA07GPS**SFUABAA**

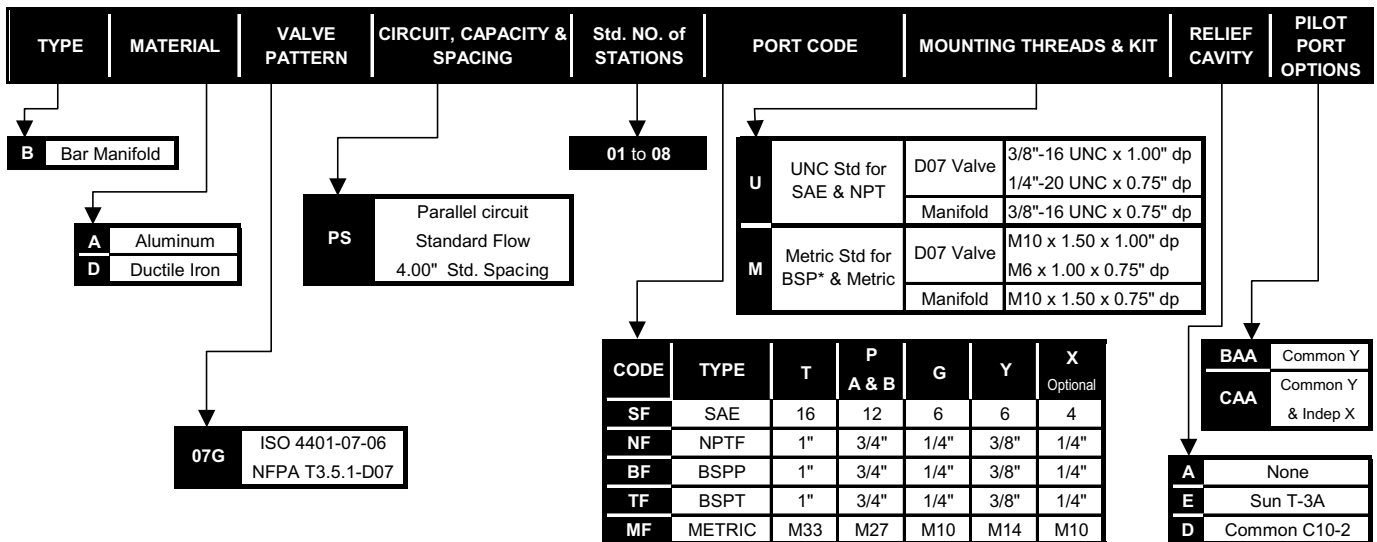

WE RESERVE THE RIGHT TO DISCONTINUE MODELS, OR CHANGE SPECIFICATIONS WITHOUT NOTICE OR INCURRING OBLIGATION

Lynch Products Can Be Modified to Suit Your Application

Phone: 1 (888) 626-4365 or +1 (905) 363-2400 Fax: 1 (800) 263-5807 www.lynch.ca sales@lynch.ca