

# D10 High Flow Parallel Circuit with Flange Ports

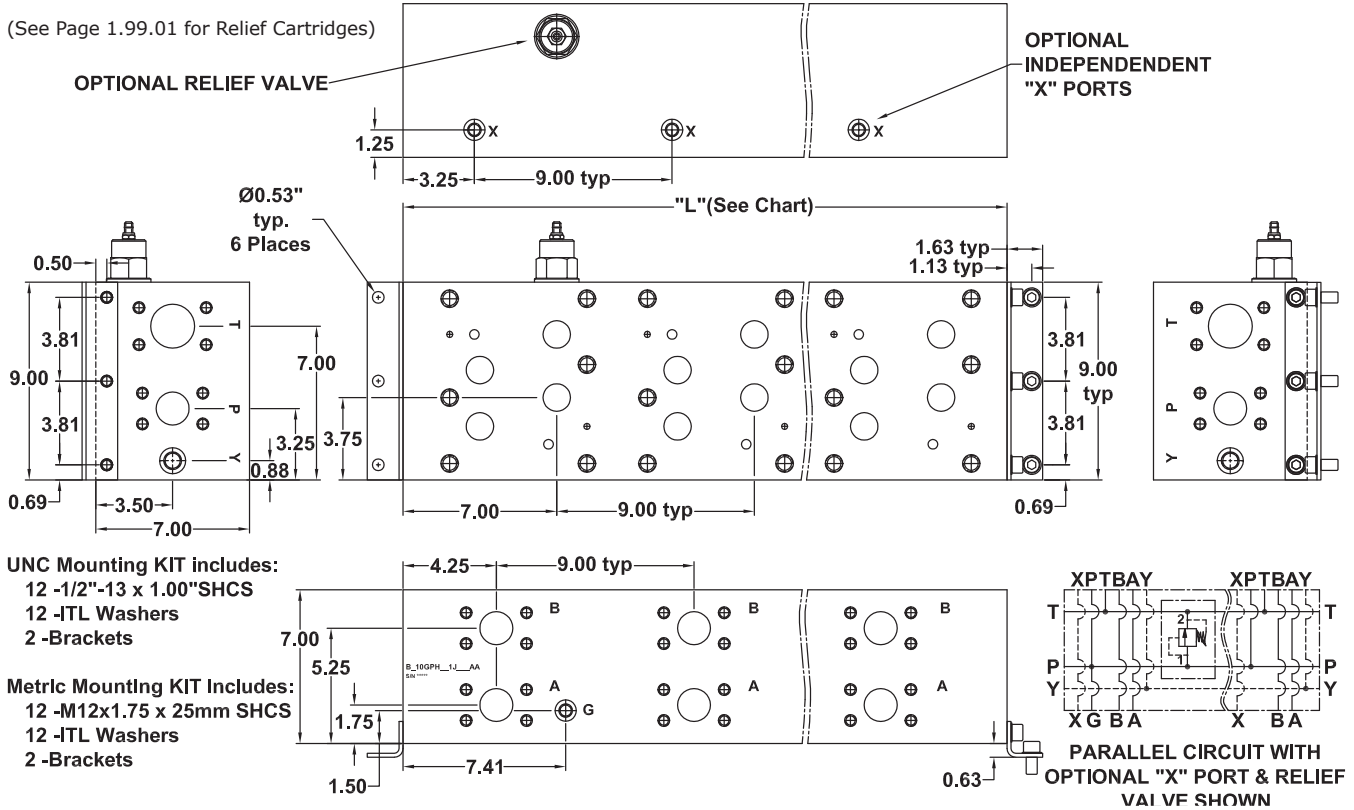

No. of Stations	1	2	3	4
Dim. "L", 9.00" spacing	10.00	19.00	28.00	37.00
est. weight in lb. - alum	46	87	128	169
est. weight in lb. - iron	123	234	345	456

SHADED AREA AVAILABLE ON SPECIAL ORDER ONLY

**Notes:**

- 1) Isolations on P & T available - See Page 5 for Codes
- 2) Common X port option available - contact factory for P/N
- 3) Wide Spacing Option - contact factory

**PART NUMBER SYSTEM**

Aluminum D10 with 9.00" spacing, Common Y & Flange porting example: BA10GPH\*\*1JUABAA

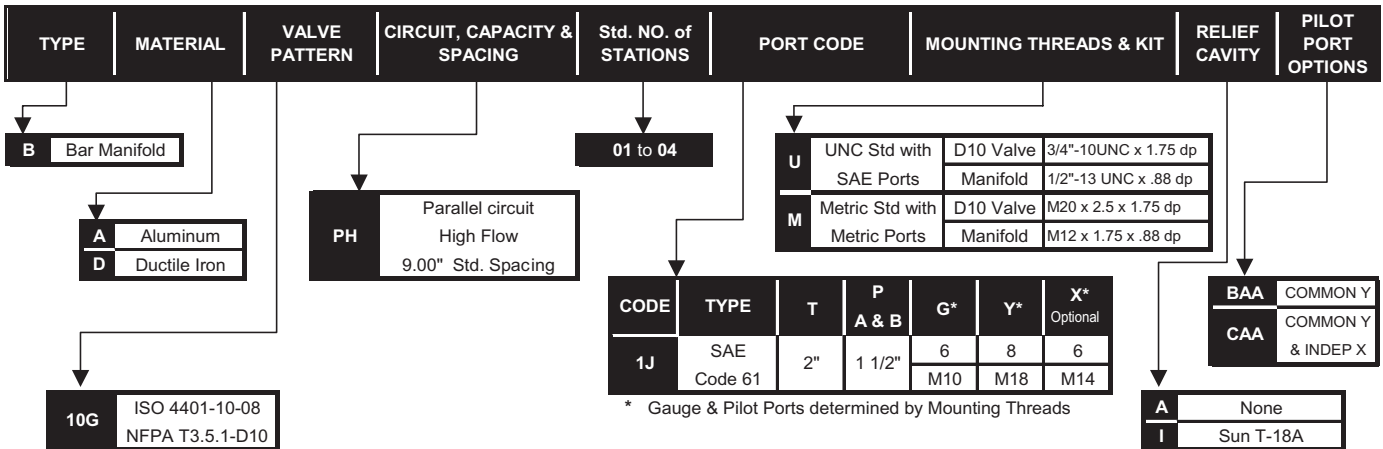

WE RESERVE THE RIGHT TO DISCONTINUE MODELS, OR CHANGE SPECIFICATIONS WITHOUT NOTICE OR INCURRING OBLIGATION

**Lynch Products Can Be Modified to Suit Your Application**

Phone: 1 (888) 626-4365 or +1 (905) 363-2400 Fax: 1 (800) 263-5807 www.lynch.ca sales@lynch.ca