

D03 High Flow Parallel Circuit Manifold

(See Page 1.99.01 for Relief Cartridges)

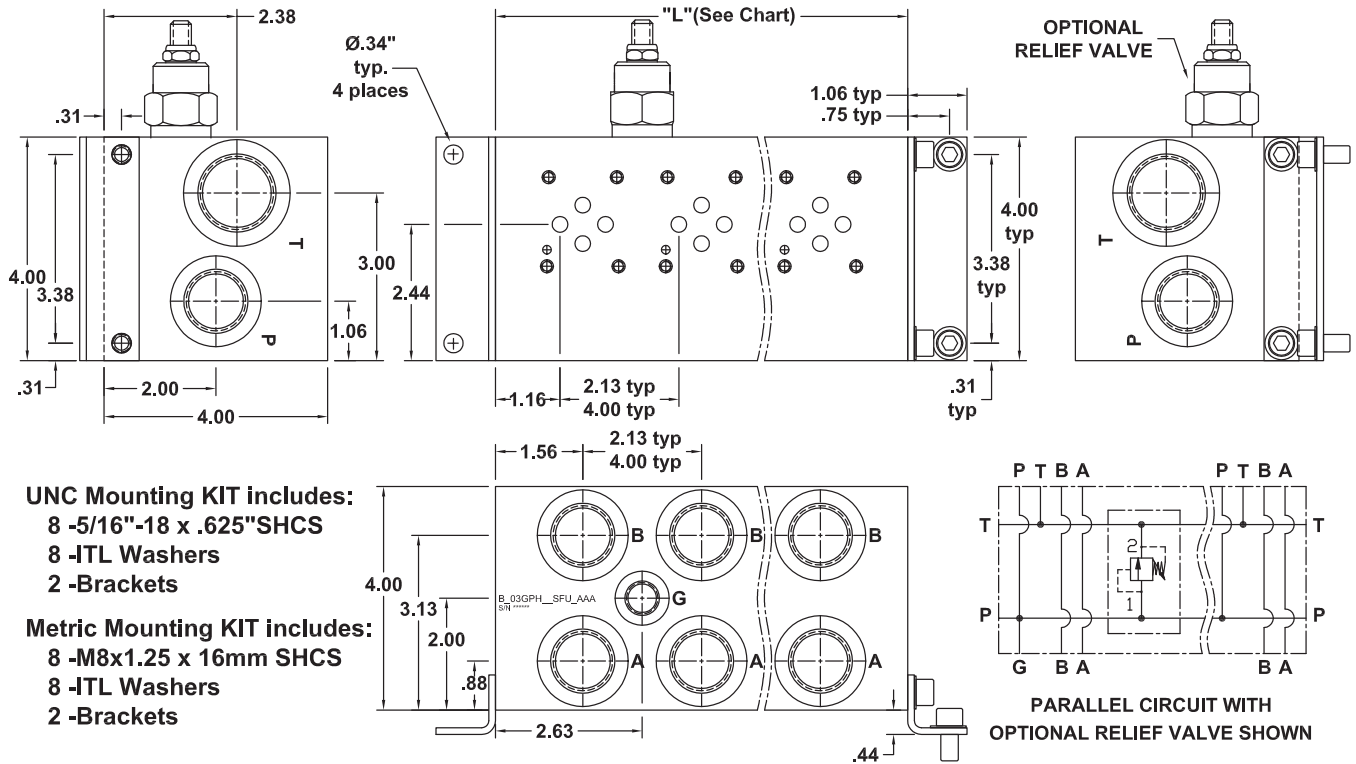

- UNC Mounting KIT includes:**
 8 -5/16"-18 x .625"SHCS
 8 -ITL Washers
 2 -Brackets
- Metric Mounting KIT includes:**
 8 -M8x1.25 x 16mm SHCS
 8 -ITL Washers
 2 -Brackets

No. of Stations	1	1*	2	3	4	5	6	7	8	9	10	11	12	13	14	15	16
Dim. "L", 2.13" spacing	3.13	4.25	5.25	7.38	9.50	11.63	13.75	15.88	18.00	20.13	22.25	24.38	26.50	28.63	30.75	32.88	35.00
est. weight in lb.- alum	5	7	8	11	14	17	21	24	27	30	33	36	39	42	45	48	51
est. weight in lb.- iron	13	17	21	29	38	46	54	62	71	79	87	96	104	112	120	129	137
Dim. "L", 4.00" spacing	-	-	7.13	11.13	15.13	19.13	23.13	27.13	31.13	35.13	39.13	-	-	-	-	-	-
est. weight in lb.- alum	-	-	11	17	23	28	34	40	46	51	57	-	-	-	-	-	-
est. weight in lb.- iron	-	-	28	44	60	75	91	106	122	137	153	-	-	-	-	-	-

* DIMENSIONS FOR 1 STATION WITH RELIEF CAVITY & GAUGE PORT
 NO GAUGE PORT SUPPLIED WITH SINGLE STATION MANIFOLD
 SHADED AREA AVAILABLE ON SPECIAL ORDER ONLY

PART NUMBER SYSTEM

Aluminum D03 with 2.13" Spacing & SAE Porting example: **BA03GPH**SFUAAAA**

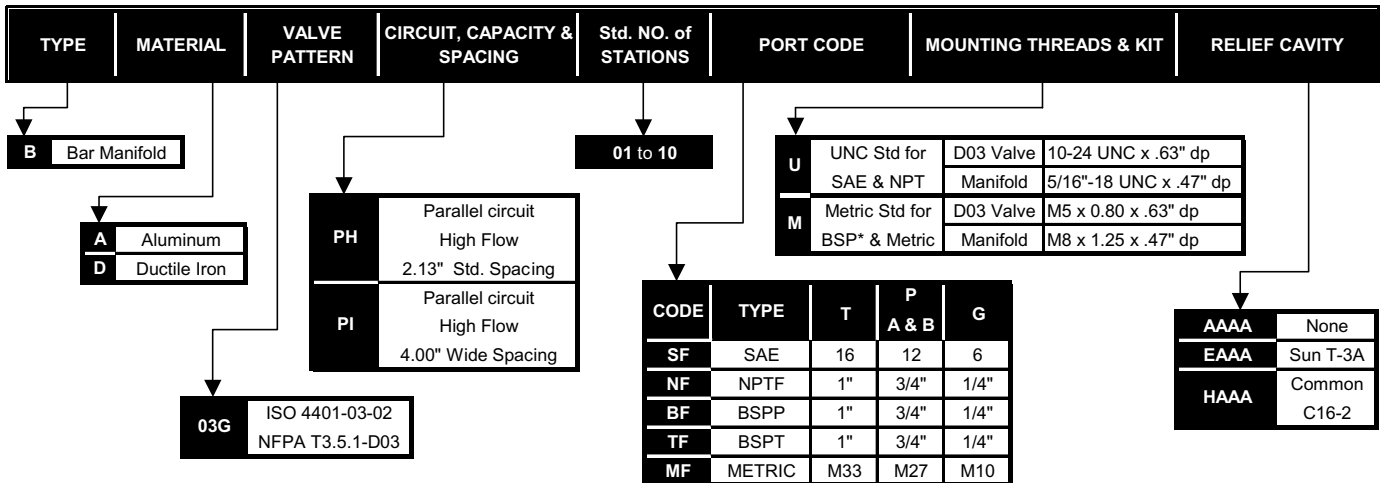

WE RESERVE THE RIGHT TO DISCONTINUE MODELS, OR CHANGE SPECIFICATIONS WITHOUT NOTICE OR INCURRING OBLIGATION

Lynch Products Can Be Modified to Suit Your Application

Phone: 1 (888) 626-4365 or +1 (905) 363-2400 Fax: 1 (800) 263-5807 www.lynch.ca sales@lynch.ca