

DWG NO RM_08G3D-D^C@\$\$#D

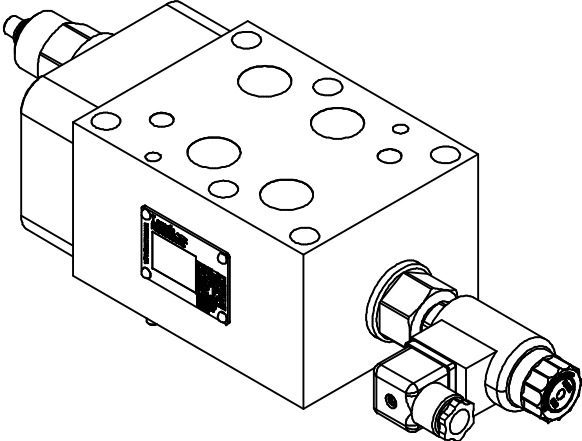

DWG NO	RM_08G3D-D^C@\$\$#D	REV	-
MODEL CODE	RM_08G3D-D^C@\$\$#D		
PROPRIETARY NOTICE	<small>THIS DRAWING DESCRIBES A PROPRIETARY PRODUCT OF LYNCH FLUID CONTROLS INC. WHICH MAY NOT BE REPRODUCED IN WHOLE OR IN PART NOR GIVEN TO A THIRD PARTY WITHOUT WRITTEN PERMISSION FROM LYNCH FLUID CONTROLS INC.</small>		
TITLE	2 Speed D08 Sandwich Module M/I B Pilot Operated Poppet Needle w/ FF Check		
DATA UNIT: INCH	3RD ANGLE PROJECTION		

MODEL CODE BREAKDOWN

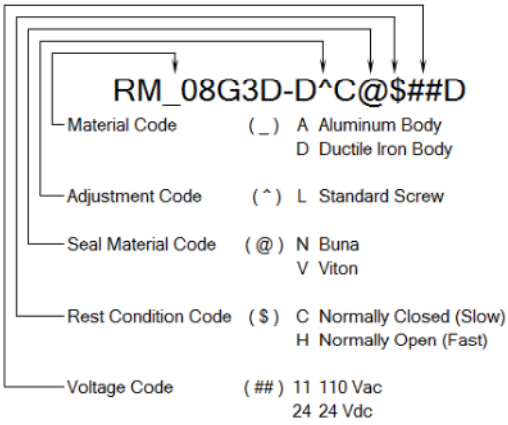

ITEM QTY		DESCRIPTION
1	1	Manifold Body
2	1	[Flow Control] Fully adjustable needle valve with reverse flow check
3	1	[Main Stage] 2-way, poppet directional valve with integral T-8A control cavity - control 2-1
4	1	[Solenoid] 2-way, solenoid-operated directional spool valve - pilot capacity
5	1	Coil
6	1	Connector
7	1	Nameplate
8	1	Nameplate
9	6	Screws

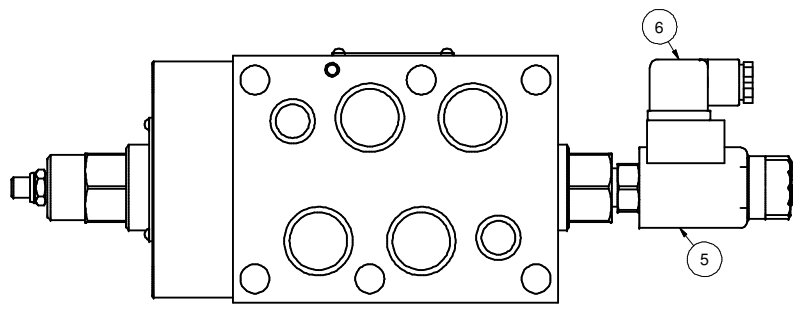
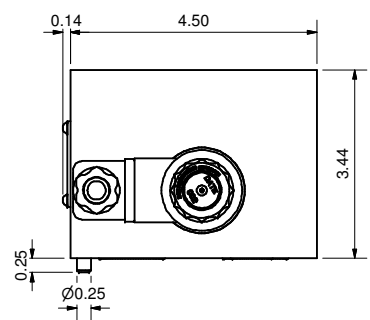
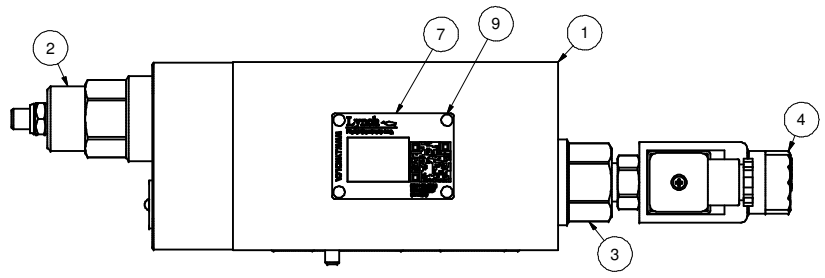
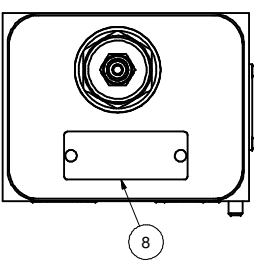
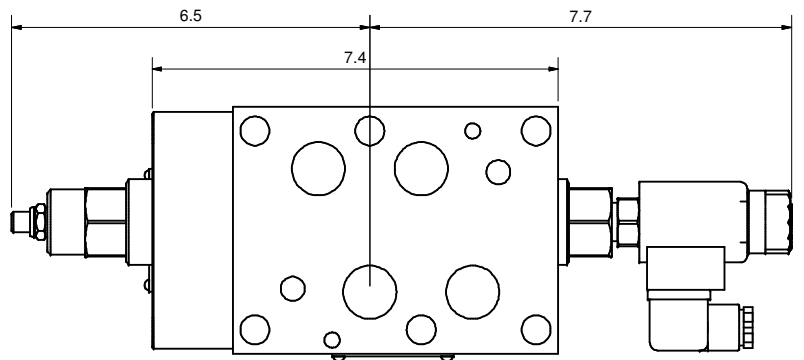
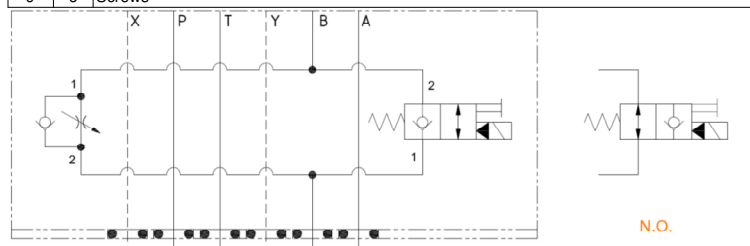



DWG NO	RM_08G3D-D^C@\$\$#D	REV	-
MODEL CODE	RM_08G3D-D^C@\$\$#D		
PROPRIETARY NOTICE THIS DRAWING DESCRIBES A PROPRIETARY PRODUCT OF LYNCH FLUID CONTROLS INC. WHICH MAY NOT BE REPRODUCED IN WHOLE OR IN PART NOR GIVEN TO A THIRD PARTY WITHOUT WRITTEN PERMISSION FROM LYNCH FLUID CONTROLS INC.		TITLE Technical Data & Non-Standard Options	
DATA UNIT: INCH	3RD ANGLE PROJECTION		

ITEM QTY		DESCRIPTION
Bill of Material		
2	1	[Flow Control] Fully adjustable needle valve with reverse flow check
2A	1	[Flow Control] Fully adjustable needle valve with reverse flow check [Hand-Knob]
2B	1	[Flow Control] Fully adjustable needle valve with reverse flow check [Calibrated Hand-Knob]

L - Standard Screw

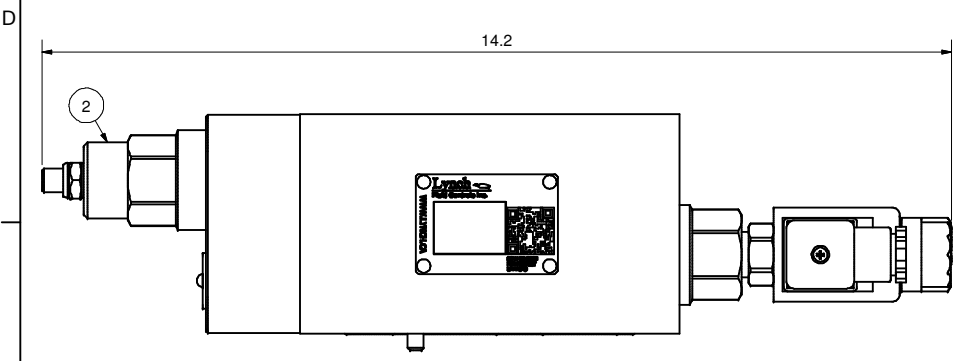

K - Hand-Knob

Non-Standard Option: Order Standard L control w/ 991 211 Kit

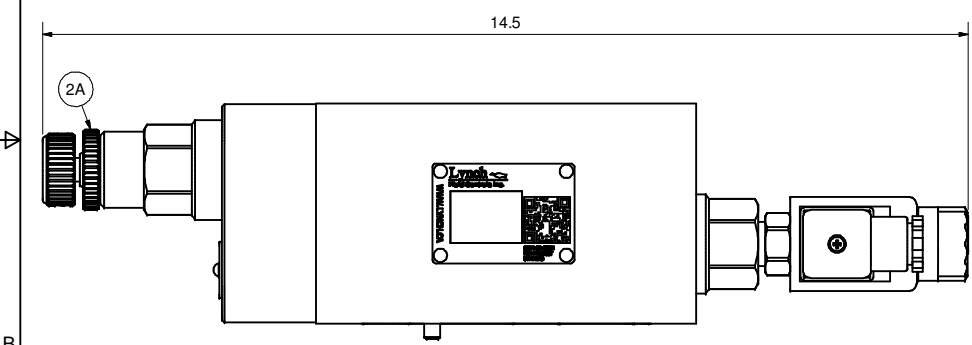

H - Calibrated Hand-Knob

Non-Standard Option

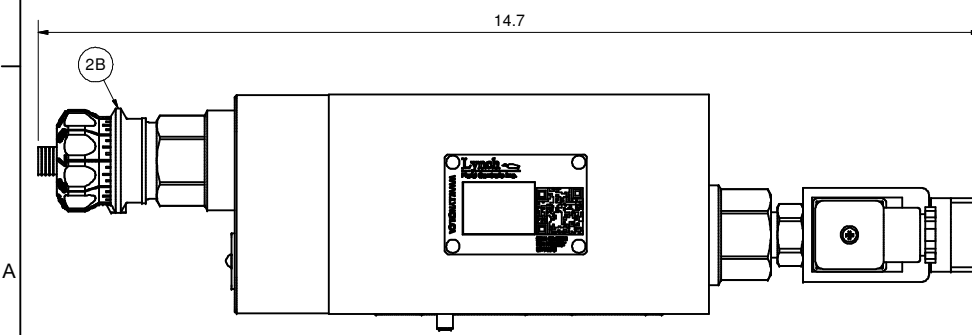

Flow Control

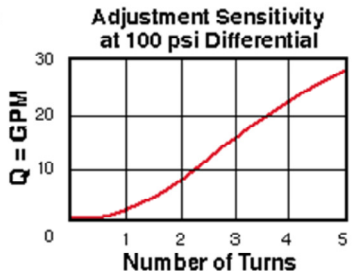
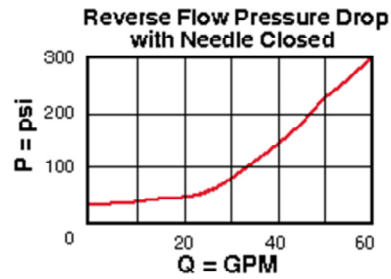

Main Stage

