

MODEL CODE BREAKDOWN

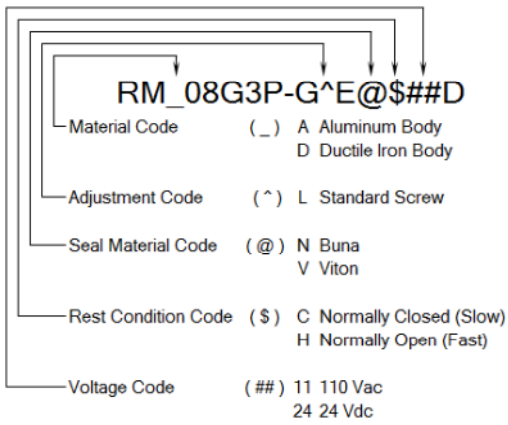

DWG NO	RM_08G3P-G^E@\$\$#D	REV	-
MODEL CODE	RM_08G3P-G^E@\$\$#D		
PROPRIETARY NOTICE	THIS DRAWING DESCRIBES A PROPRIETARY PRODUCT OF LYNCH FLUID CONTROLS INC. WHICH MAY NOT BE REPRODUCED IN WHOLE OR IN PART NOR GIVEN TO A THIRD PARTY WITHOUT WRITTEN PERMISSION FROM LYNCH FLUID CONTROLS INC.		
TITLE	2 Speed D08 Sandwich Module M/I P Pilot Operated Poppet Needle		
DATA UNIT: INCH	3RD ANGLE PROJECTION		

ITEM QTY		DESCRIPTION
1	1	Manifold Body
2	1	[Flow Control] Fully adjustable needle valve
3	1	[Main Stage] 2-way, poppet directional valve with integral T-8A control cavity - control 1-2
4	1	[Solenoid] 2-way, solenoid-operated directional spool valve - pilot capacity
5	1	Coil
6	1	Connector
7	1	Nameplate
8	1	Nameplate
9	6	Screws

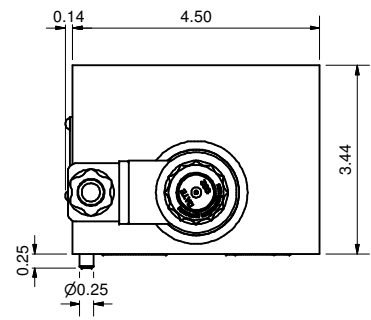
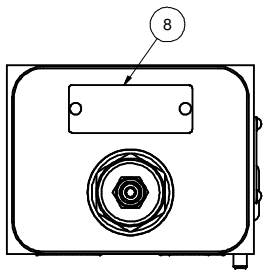
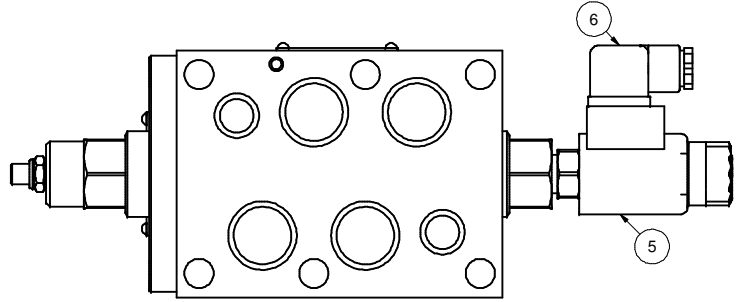
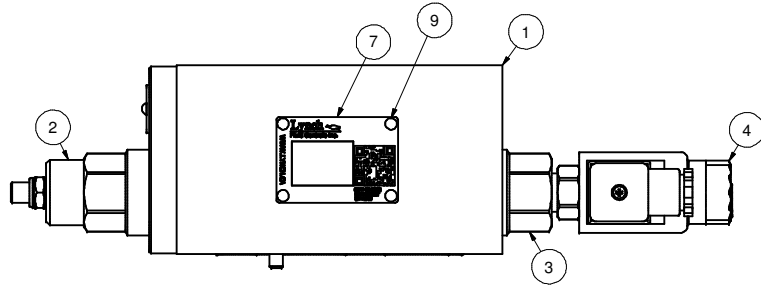
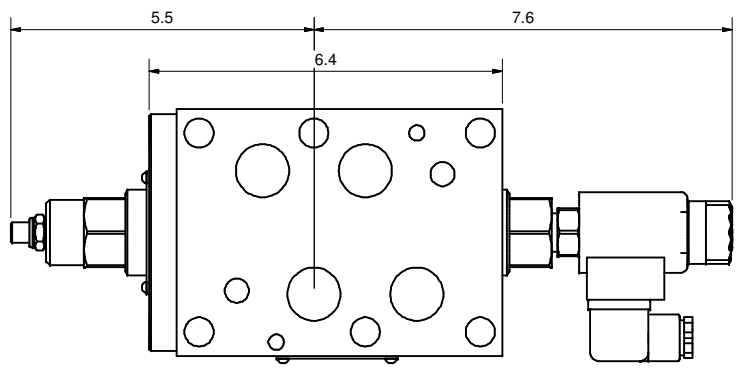
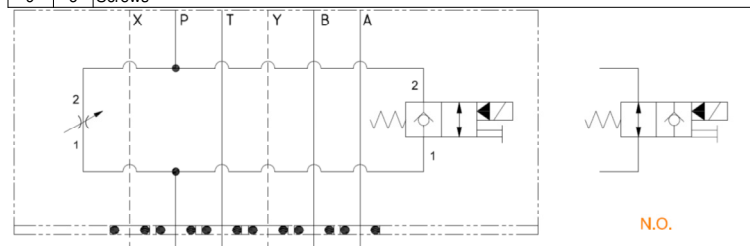

L - Standard Screw

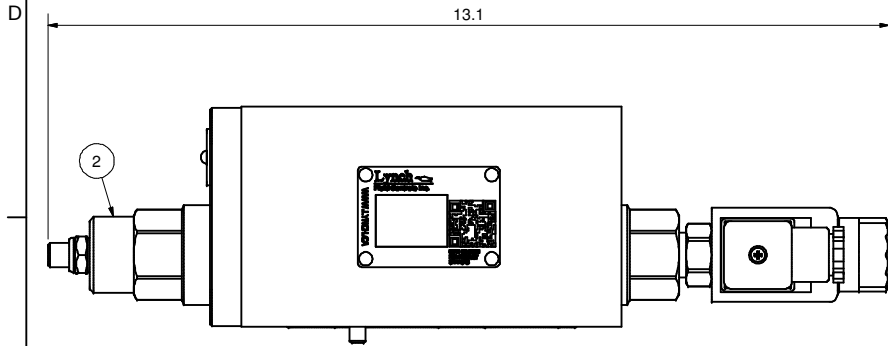

K - Hand-Knob

Non-Standard Option: Order Standard L control w/ 991 211 Kit

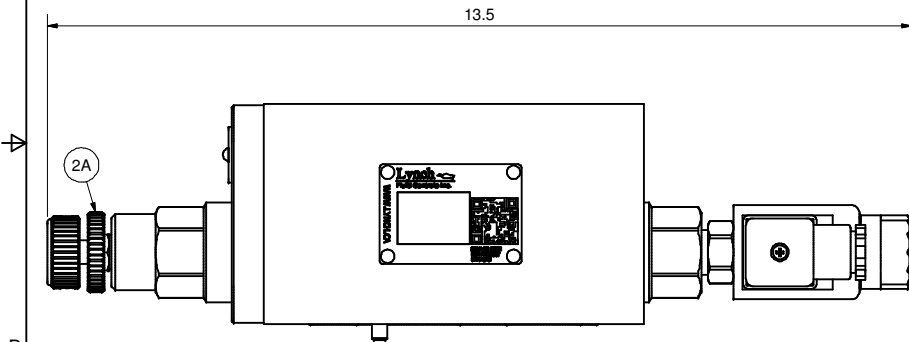

H - Calibrated Hand-Knob

Non-Standard Option

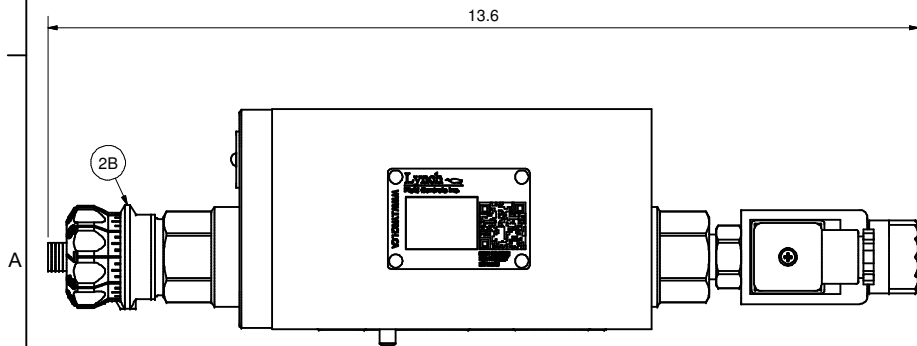

DWG NO	RM_08G3P-G^E@##D	REV	-
MODEL CODE	RM_08G3P-G^E@##D		
PROPRIETARY NOTICE THIS DRAWING DESCRIBES A PROPRIETARY PRODUCT OF LYNCH FLUID CONTROLS INC. WHICH MAY NOT BE REPRODUCED IN WHOLE OR IN PART NOR GIVEN TO A THIRD PARTY WITHOUT WRITTEN PERMISSION FROM LYNCH FLUID CONTROLS INC.		TITLE Technical Data & Non-Standard Options	
DATA UNIT: INCH	3RD ANGLE PROJECTION		

ITEM QTY		DESCRIPTION
Bill of Material		
2	1	[Flow Control] Fully adjustable needle valve
2A	1	[Flow Control] Fully adjustable needle valve [Hand-Knob]
2B	1	[Flow Control] Fully adjustable needle valve [Calibrated Hand-Knob]

Flow Control

Adjustment Sensitivity at 100 psi Differential

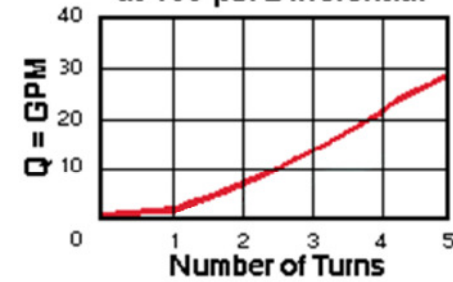

Main Stage

PSI Pressure Differential vs Flow

