

MODEL CODE BREAKDOWN

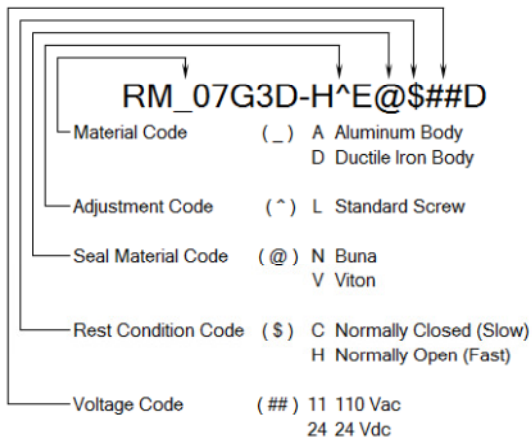

DWG NO	RM_07G3D-H^E@\$##D	REV	-
MODEL CODE	RM_07G3D-H^E@\$##D		
PROPRIETARY NOTICE	TITLE		
THIS DRAWING DESCRIBES A PROPRIETARY PRODUCT OF LYNCH FLUID CONTROLS INC. WHICH MAY NOT BE REPRODUCED IN WHOLE OR IN PART NOR GIVEN TO A THIRD PARTY WITHOUT WRITTEN PERMISSION FROM LYNCH FLUID CONTROLS INC.	2 Speed D07 Sandwich Module M/I B Pilot Operated Poppet Needle		
DATA UNIT: INCH	3RD ANGLE PROJECTION		

ITEM QTY		DESCRIPTION
1	1	Manifold Body
2	1	Seal Plate
3	1	[Flow Control] Fully adjustable needle valve
4	1	[Main Stage] 2-way, poppet directional valve with integral T-8A control cavity - control 2-1
5	1	[Solenoid] 2-way, solenoid-operated directional spool valve - pilot capacity
6	1	Coil
7	1	Connector
8	1	Nameplate
9	1	Nameplate
10	6	Screws

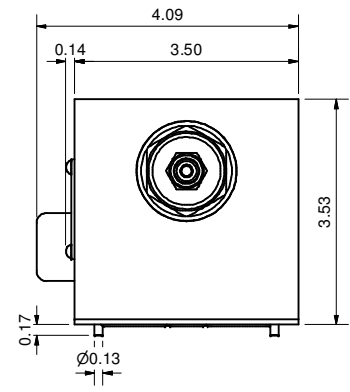
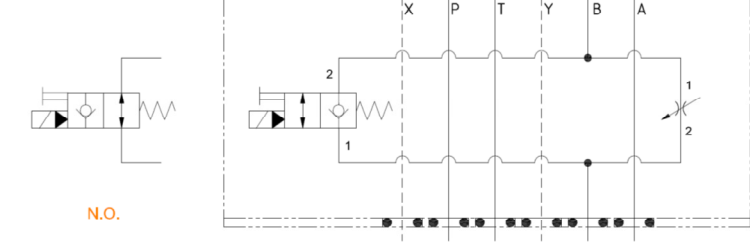
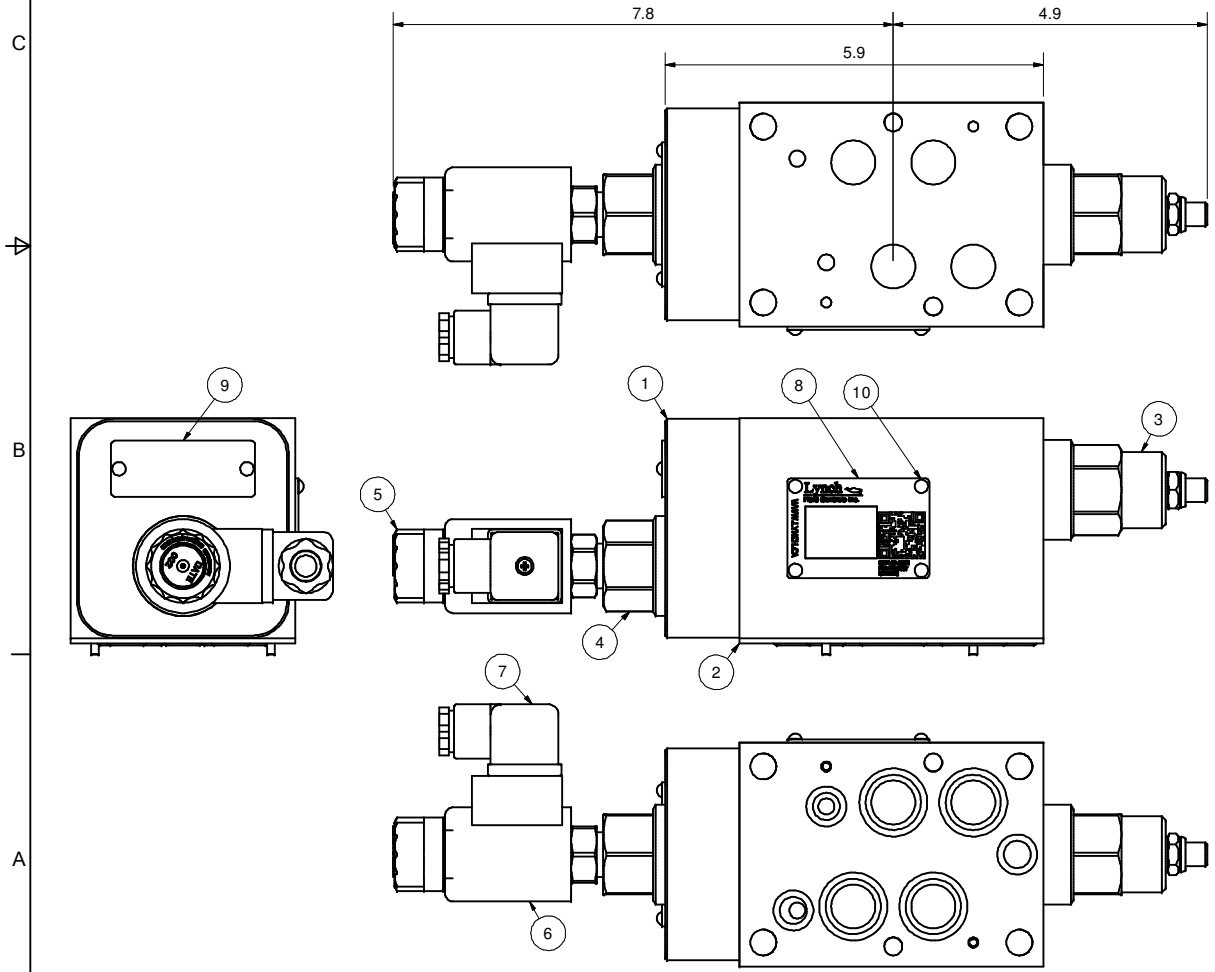

DWG NO RM_07G3D-H^E@\$##D

L - Standard Screw

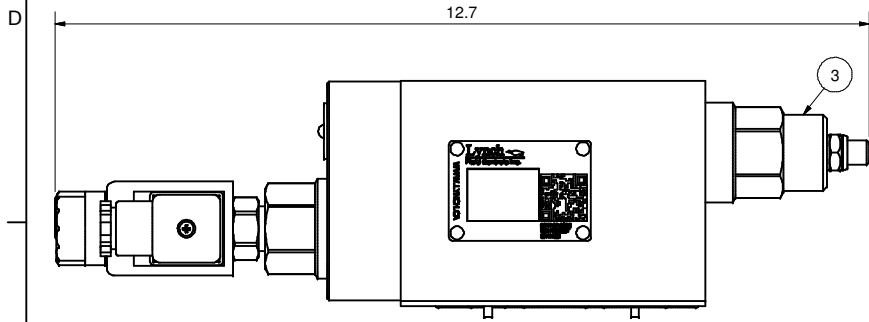

K - Hand-Knob

Non-Standard Option: Order Standard L control w/ 991 211 Kit

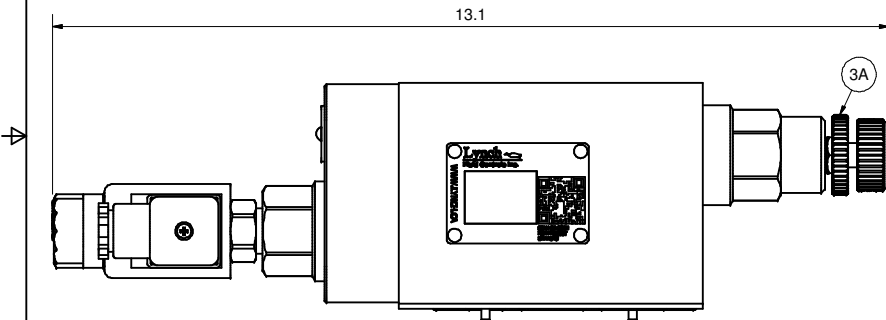

H - Calibrated Hand-Knob

Non-Standard Option

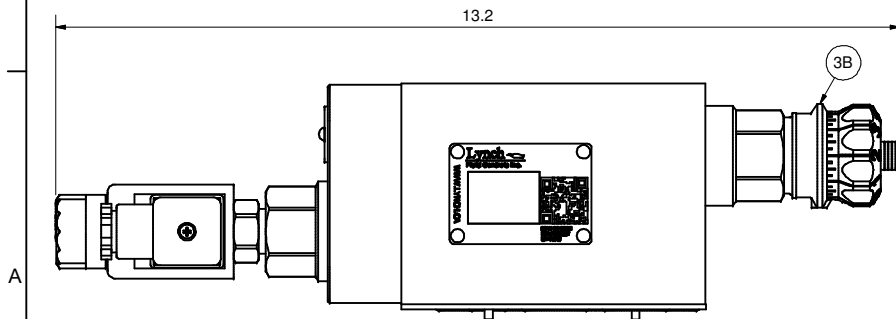

DWG NO RM_07G3D-H^E@##D REV -

MODEL CODE RM_07G3D-H^E@##D

PROPRIETARY NOTICE
THIS DRAWING DESCRIBES A PROPRIETARY PRODUCT OF LYNCH FLUID CONTROLS INC. WHICH MAY NOT BE REPRODUCED IN WHOLE OR IN PART NOR GIVEN TO A THIRD PARTY WITHOUT WRITTEN PERMISSION FROM LYNCH FLUID CONTROLS INC.

TITLE
Technical Data & Non-Standard Options

DATA UNIT: INCH 3RD ANGLE PROJECTION

ITEM QTY		DESCRIPTION
3	1	[Flow Control] Fully adjustable needle valve
3A	1	[Flow Control] Fully adjustable needle valve [Hand-Knob]
3B	1	[Flow Control] Fully adjustable needle valve [Calibrated Hand-Knob]

Flow Control

Adjustment Sensitivity at 100 psi Differential



Main Stage

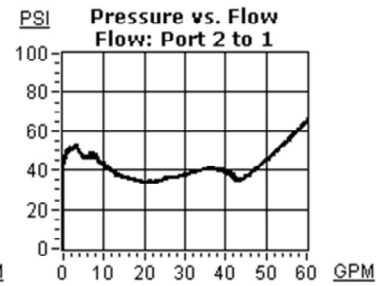
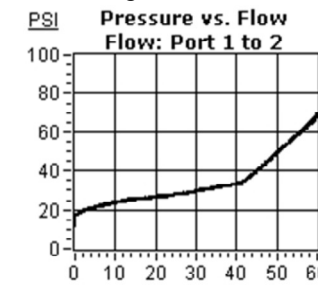

DWG NO RM_07G3D-H^E@##D

A

B

C

D